Table of Contents

M Engines

Subject	Page
Motorsport Engines History	6
Motorsport Engine History	6
S38 (M88)	6
S14	7
S50 (US)	8
S52	8
S54	9
S62	10
Formula One Engine	11
S65	14
S85B50 Engine	18
Engine Block and Bedplate	18
Bedplate Sealing	19
Oil Pan	19
Crankshaft	19
Connecting Rods	19
Pistons	20
Cylinder Head and Valvetrain	20
Cylinder Head Cover	20
Valves	20
Valve Springs	21
Valve Keepers	21

Table of Contents

Subject	Page
Hydraulic Valve Actuators (HVA)	21
Camshaft	22
Camshaft Drive	22
VANOS	22
VANOS Actuators	24
VANOS Gear Mechanism	26
VANOS High Pressure Pump	29
Lubrication System	32
Oil Pumps	33
Electric Oil Pumps	35
Oil Spray Nozzles	35
Oil Filter Housing	35
Cooling System	36
Radiator	36
Thermostat	36
Water Pump	36
Throttle Valves	37
Idle Control	37
Secondary Air System	38
Exhaust System	38
S65B40 Engine	59
Engine Block with Bedplate Construction	59
Crankshaft	60
Connecting Rods	60
Pistons	60
Oil Supply	61

Table of Contents

Subject	Page
Cylinder Head	63
Hydraulic Bucket Tappet	64
Camshaft Drive	64
VANOS	65
Individual Throttle Body System	68
Air Intake System	69
Secondary Air System	70
Oil Separators	70
Cooling System	71
Fuel System	73
Exhaust System	74
S54B32 Engine	76
Engine Block	77
Crankshaft and Bearings	77
Connecting Rods and Bearings	78
Pistons and Piston Rings	78
Oil Pump	79
Testing Oil Pressure	79
Crankcase Ventilation	80
Cylinder Head	81
Camshaft Drive	82
Camshafts	82
Valve Train	83
Valves	85
Valve Springs	85
VANOS	86

Table of Contents

Subject	Page
VANOS Unit	86
VANOS Hydraulic System	90
Workshop Hints	91
Intake Air Plenum	92
Intake Air System	92
Fuel Supply	93
Clutch Assembly	93
Exhaust System	93

M Engines

Model: E9X M3, E60 M5, E63/E64 M6, E85/E86 M Roadster and M Coupe

Production: From Start of Production

OBJECTIVES

After completion of this module you will be able to:

- Understand the construction of the current Motorsport engines.
- Identify engine components.
- Perform basic engine services on the S85 and S54 engines.

Motorsport Engines History

Motorsport Engine History

Since 1972, BMW M GmbH, the “motorsport” division of BMW has been turning out some of the most powerful and legendary engine packages in the auto industry. The letter “M” has been referred to as “the most powerful letter in the world”. Customers who are familiar with the “M” badge know that when they buy an M-car, they have come to expect something special under the hood.



M1

S38 (M88)

The first BMW motorsport engine was the in-line 6-cylinder known then as the M88. This engine was introduced with the legendary M1 in 1978. Since then, the M88 engine has been known as the S38 in production vehicles. In the M1, the M88 produced 277hp which was impressive for a 6-cylinder engine in 1978.

The S38 engine, which was a slightly “de-tuned” version of the M88, was first introduced into the US market in the E28 M5 in 1988. The 256 hp S38 featured some of the BMW motorsport philosophy which is still in use today.

Innovations such as individual throttles, 4 valves per cylinder, light-weight valvetrain and steel crankshaft are still in use on current M engines.

The E24 M6 also took advantage of the S38 engine technology through its production life. The M6 was available in the US in 1987 and 1988.



E28 M5

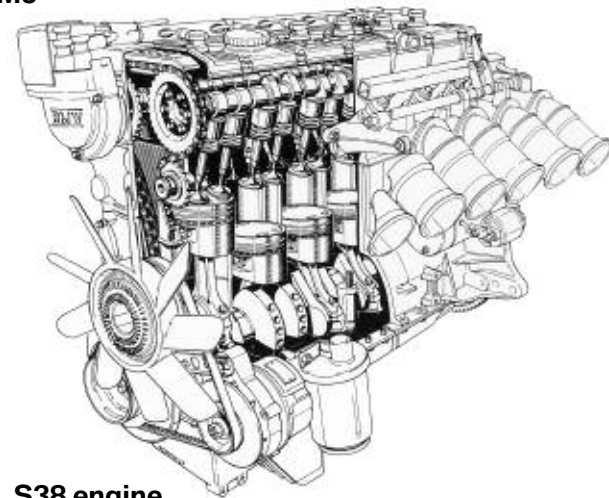

S38 engine

S14

BMW produced a “Motorsport” version of the E30 which was introduced a year before the M5. The first M3 featured a Formula One derived race bred powerplant that came to be known as the S14. The S14 was a 2.3 liter, 4-cylinder engine capable of 192 hp at 6750 rpm. Considering that this is a “naturally aspirated” engine, a 4-cylinder engine producing 192 horsepower was impressive especially in 1987.



E30 M3

The S14 engine was a further development of the 4-cylinder engine which was used to propel the BMW Brabham F1 car to the 1983 F1 World Championship. The Formula 1 engine (M12/M13) was derived from the “stock block” M10 engine. The M12/M13 F1 engine displaced 1.5 liters, was turbocharged and capable of producing in excess of 1100 bhp. This is an impressive feat for an engine which was developed from a stock powerplant. The extensive research and development of the Formula 1 engine led to the S14 engine ultimate production of the S14.

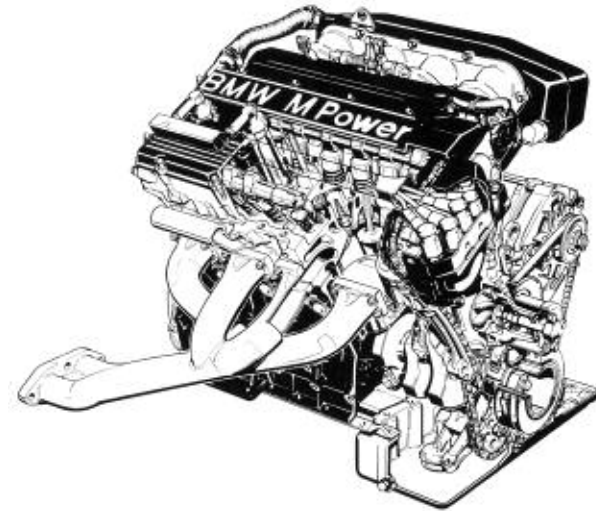

S14 engine

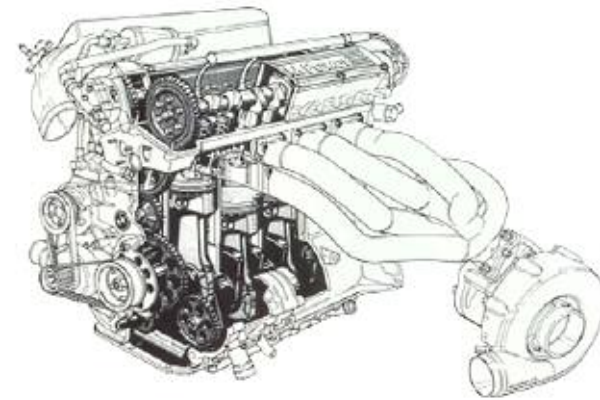

Formula 1 engine (M12/M13)

S50 (US)

The E30 M3 was discontinued in 1991. The next generation M3 would not be available until 1995. The E36 M3 was based on the new 3 series coupe introduced in 1991. This was the first time that a 6-cylinder was available in the M3.

The new S50 (US) engine was derived from the M50TU already in use at that time. The new M3 engine produced 240 hp and differed considerably from the European version. The S50 (US) engine was only available for one year (1995). In order to comply with OBD II regulations, the S50 was discontinued in favor of the S52 in 1996. The S52 was a 3.2 liter engine using Siemens engine management.

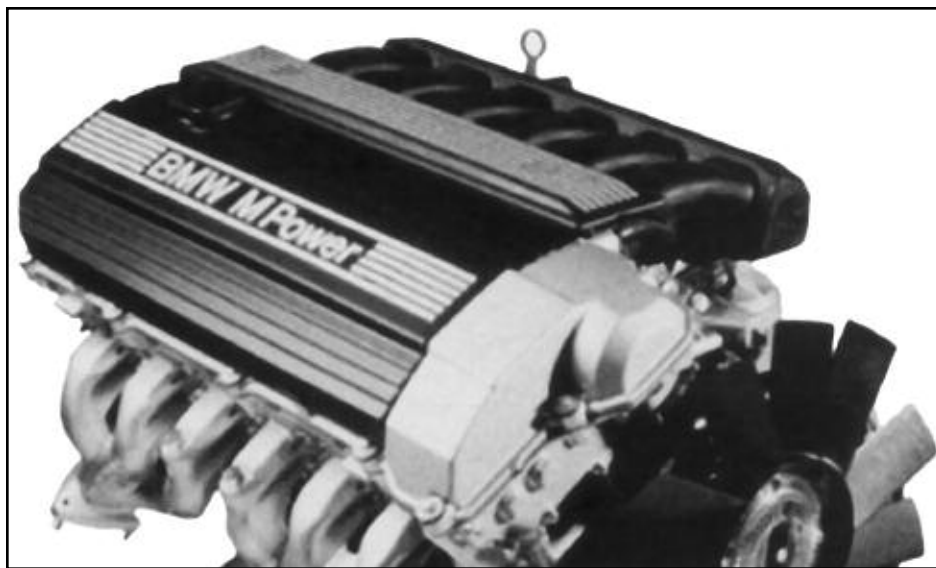

S52

In 1996, the M3 received the new S52 3.2 liter engine which produced 240 hp. This was the first OBDII compliant "M" engine and also the first to use Siemens engine management instead of Bosch.

The engine was based on the M52 production engine and used much of the same technology as the previous (S50 US) engine. The S52 was also used in the "M" Roadster and Coupe. The S52 would be in use until 2001, when it was replaced by the S54.

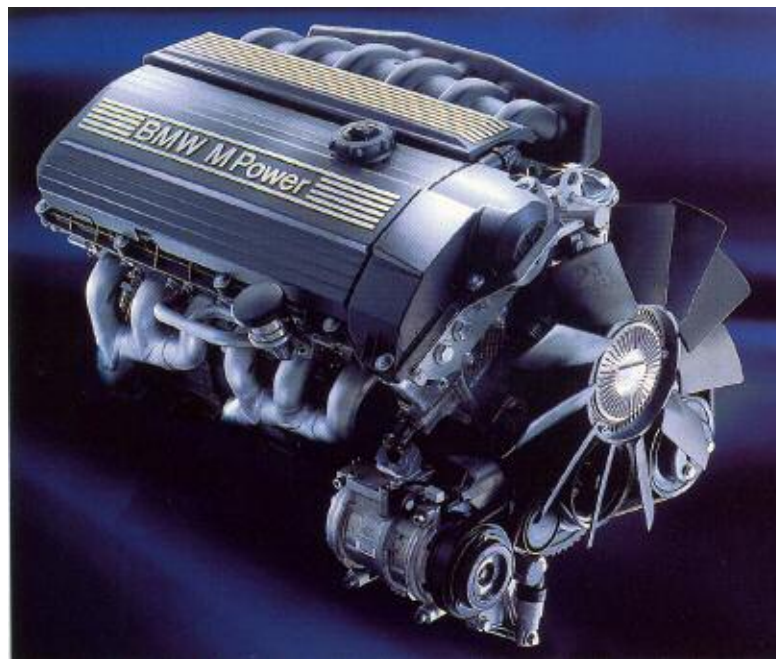

S54

The S54 would be the powerplant of choice for the 3rd generation M3. The new in-line 6-cylinder “M” engine marked a major leap in engine technology for that time. For the first time in a production “M” car, the S54 achieved the elusive goal of 100 hp per liter. With 333 hp at 7900 RPM, S54 propelled the E46 M3 to 0-60 times of 4.8 seconds. The engine is also installed in the M Roadster and M Coupe.



The S54 was the first Motorsport 6-cylinder to use the “High-Pressure Double VANOS” system.

Some of the other engine highlights include:

- 11.5 to 1 compression
- 6 individual throttle assemblies with electronic throttle control
- A unique lightweight valve actuating mechanism
- Forged steel crankshaft with “nitro-carburized” heat treatment
- “Semi-dry sump” lubrication system
- Light weight one-piece cylinder head
- High-strength cast iron engine block

Together with the Motorsport designed engine management system, the S54 also meets the required LEV emission standards as well.

S62

Another first time achievement for the Motorsport division, was the introduction of the first V-8 “M” engine. The 5 liter S62 was also the most powerful production “M” engine with an output of 394hp.

The S62 was first used in the third generation M5, the E39. Also, the S62 was used in the Z8 which marks only the second time in which an “M” engine was used in a non-”M” vehicle. The first time being the S70 in the E31 850Csi.

Features of the S62 engine include:

- 8 individual throttle controlled electronically via two throttle motors
- Hi-pressure Double VANOS
- Lightweight aluminum block and cylinder heads
- Lightweight valvetrain
- “Semi-dry sump” oiling system



E39 M5



E39 M5 S62 engine

Formula One Engine

The S85 engine has benefitted greatly from the lessons learned in Formula 1. The F1 counterpart of the S85 is known as the P84/5. This is a 3 liter V-10 which consists of approximately 5000 parts and requires around 100 hours of assembly time.

The engine block and cylinder heads are constructed of aluminum alloy and are designed to withstand the demands and stresses of an F1 race. The titanium connecting rods are just one example of components which allow the P84/5 to reach engine speeds of more than 19,000 RPM.

Some interesting facts of the F1 V-10:

- During the design of the F1 V-10 approximately 1000 technical drawings are created.
- The total engine weighs less than 195 pounds.

- The exhaust temperature can reach up to 1620°F.
- The air temperature in the pneumatic valve system can reach 450°F.
- Before the recent changes in F1 rules regarding engines, BMW produced about 200 engines per race season.
- The P84/5 engine propels the FW27 F1 car to 120mph in five seconds.
- At 19,000 RPM the following events occur in one second - The engine rotates 316.7 revolutions, the ignition system fires 1,583 times, 9,500 engine speed measurements are made, the pistons covers a distance of 75 yards and nearly 140 gallons of air are drawn into the engine.

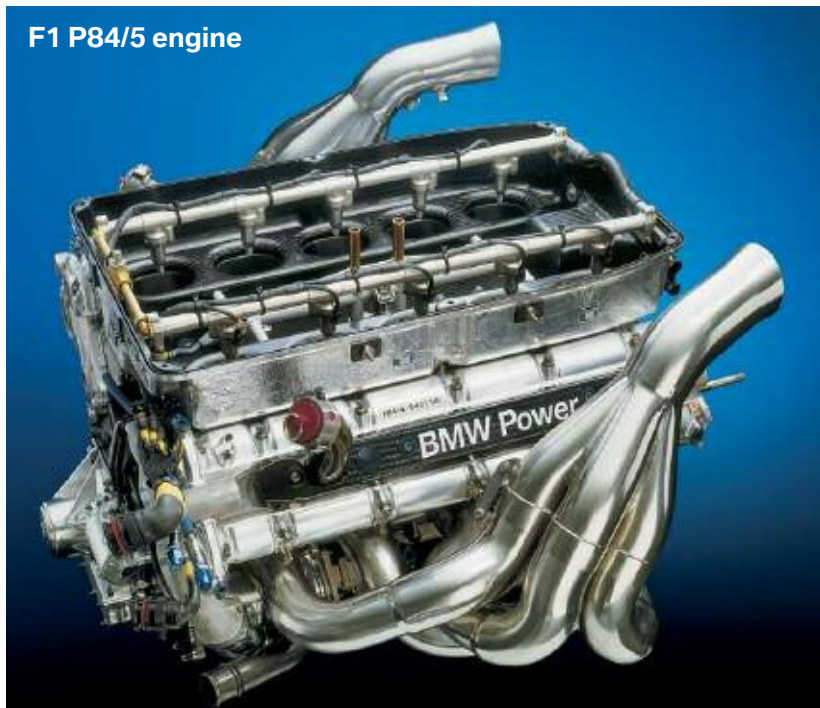

S85

For the first time in a road-going BMW, a Formula 1 inspired V-10 has been developed for the new M5 and M6. The S85 engine benefits from the knowledge gained from F1 racing development.

Together with all of the other engine concepts in this design, the S85 propels the E6x M5 and M6 to sub-5 second 0-60 mph times. The M5 offers the best power to weight ratio in comparison with the other vehicles in it's class.



The all aluminum V-10 produces in excess of 500 horsepower at 7750 RPM. One of the concepts adapted from F1 is the “High RPM Power Concept” which allows the S85 to achieve a maximum RPM of 8250.

Other features of the S85 include a light alloy, 2-piece crankcase which uses a bedplate design for additional reinforcement. The familiar High-Pressure Double VANOS is carried over from previous BMW Motorsport engine designs.

The S85 is naturally aspirated and “breathes” through 10 individual throttle assemblies which are actuated by two throttle motors (One per bank).



S85B50 Engine Statistics

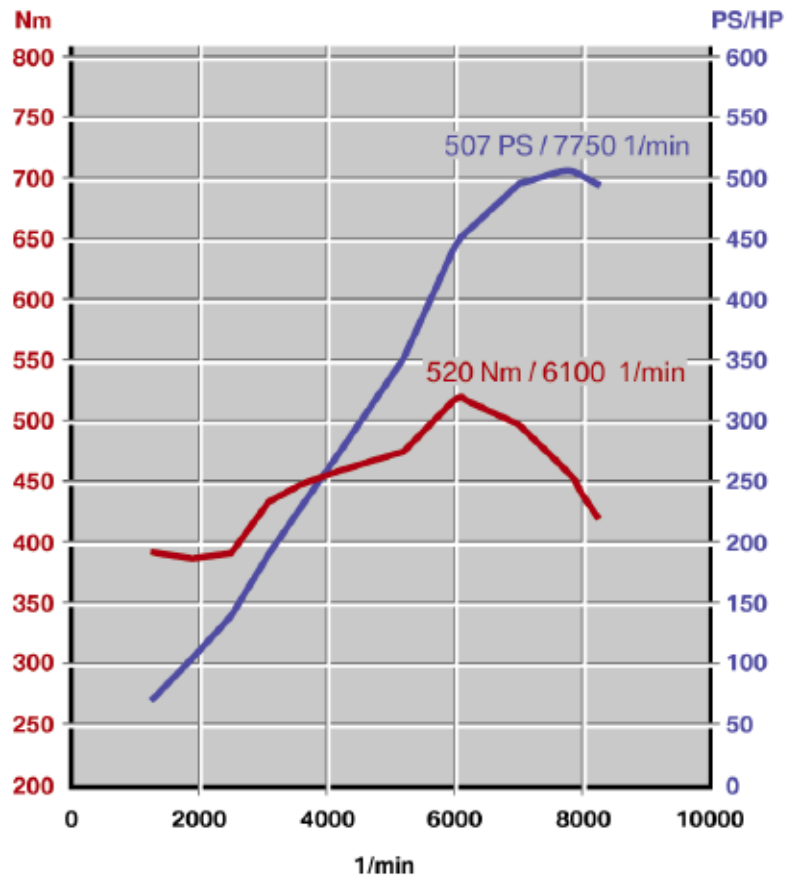

Description	S85 V-10	P84/5 F1 V-10
Engine Configuration	90 Degree V-10, 4 valves per cylinder	90 Degree V-10, 4 valves per cylinder
Displacement	4,999 cm ³ (5.0 Liter)	2,999 cm ³ (3.0 Liter)
Bore and Stroke	92mm X 75.2 mm	Unknown
Horsepower	373kW (500bhp) @7750	900 hp +
Torque	520Nm @ 6100RPM	Unknown
Maximum engine RPM	8250	19,200
Compression	12 to 1	Unknown

S65

For the first time ever a V8 engine has been fitted in a series production M3. The main concept behind this high-revving, high performance engine with a sporty sound is the extremely light, rigid and robust construction which is capable of reaching extreme engine speeds of up to 8,400 rpm. The engine achieves an impressive 414 hp (roughly 100 hp per liter).

The S65B40 is derived from its big brother, the S85B50. The main changes can be seen in the engine oil system, VANOS valve gear system and air intake system. Special consideration has also been given to engine weight optimization.



The engine with all its assemblies is built in the special engine production area of the Munich BMW plant.

The M engineers consider the high engine speed concept to be the most intelligent strategy of obtaining the maximum thrust from a vehicle.

For example, in a modern formula 1 engine, the crankshaft works at up to 19,000 rpm (resulting in piston speeds of over 25 meters per second).

Description	S85 V-10	S65 V-8
Engine Configuration	90 Degree V-10, 4 valves per cylinder	90 Degree V-8, 4 valves per cylinder
Displacement	4,999 cm ³ (5.0 Liter)	3,999 cm ³ (4.0 Liter)
Bore and Stroke	92mm X 75.2 mm	92mm X 75.2 mm
Horsepower	373kW (500bhp) @7750	414 hp @ 8,400 RPM
Torque	520Nm @ 6100RPM	400 Nm @ 3,900 rpm
Maximum engine RPM	8250	8,400
Compression	12 to 1	12 to 1

The actual thrust at the driven wheels is the decisive factor for car acceleration. This thrust is achieved by the engine speed, the torque and the short gear ratio.

This concept has been adopted for vehicles in the 'M' range from motor sport. The fully variable M limited-slip differential means that the thrust is optimally distributed to the live axle.

Furthermore, the S65B40 also includes the established M-specific features such as double VANOS, individual throttle butterflies and high-performance engine electronics (MSS60 control unit).



S65 eight individual throttle valves

Technical workarounds by increasing the cylinder capacity or boosting become excessive, thus avoiding the increased engine weight and consumption often associated with these methods.

The high engine speed concept helps to achieve dynamically agile handling and the maximum in sports driving performance characteristics.

A maximum torque of 400 Newton meters at 3,900 rpm is reached. Approx. 85 percent (340 Nm) can be utilized beyond the enormous engine speed range of 6,500 rpm.

The S65B40 attains 8,400 rpm, and therefore a value that was previously only reserved for racing car engines or exotic custom vehicles.

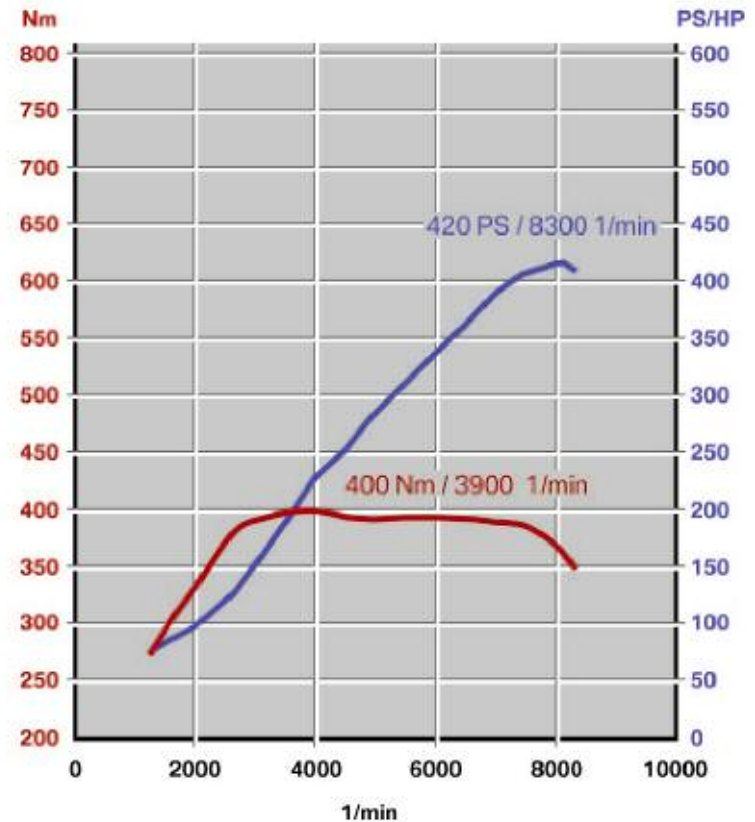

Note: For safety reasons, due to the engine dynamics when the vehicle is stationary (i.e. without a road-speed signal), the rev limit is set to 7,000 rpm to prevent the engine from over revving.

BMW Motorsport Engine Summary					
Designation	# of cyl.	Displacement (Liters)	Output (horsepower)	Vehicle (year)	Comments
S14	I-4	2.3	192 hp	E30 M3 (87-91)	First 4-cylinder Motorsport engine
S38 (M88)	I-6	3.5 (M1) 3.5 (E28/E24) 3.6 (E34)	277hp 256 hp 310hp	M1 (1978-81) E28 (88)/E24 (87-88) E34 (91-93)	First production Motorsport engine.
S50US	I-6	3.0	240 hp	E36 M3 (95)	Used in 1995 only
S52	I-6	3.2	240 hp	E36 M3 (96-99) E36/7 M Roadster E36/7 M Coupe	OBD II compliant
S54	I-6	3.2	333 hp	E46 M3 (01-05) E86 M Coupe and E85 M Roadster	Adjustable Valvetrain
S62	V-8	5.0	394 hp	E39 M5 (00-04) E52 Z8	First V-8 motorsport engine
S85	V-10	5.0	500 hp	E60 M5 (07-) E63/E64 M6 (07-)	First V-10 motorsport engine
S70	V-12	5.6	375 hp	E31 850CSI (94-95)	Used in the 850Csi
M12/M13	I-4	1.5	over 1100 hp	Brabham BMW F1 BT53 1983	1983 Formula 1 championship winning engine
P84/5	V-10	3.0	over 900 hp	BMW Williams F1	Formula 1 V-10 engine
S65	V-8	4.0	414hp	E9X M3 (08-)	Low pressure Vanos, first V8 in an M3
S63	V-8	5.0	550hp	X6 M and X5 M (09-)	Twin scroll twin turbos in the engine valley, first xDrive M vehicle

NOTES

PAGE

S85B50 Engine

Engine Block and Bedplate

Similar in design to the N52 engine, the S85 takes advantage of the additional stiffening properties of the 2-piece crankcase.

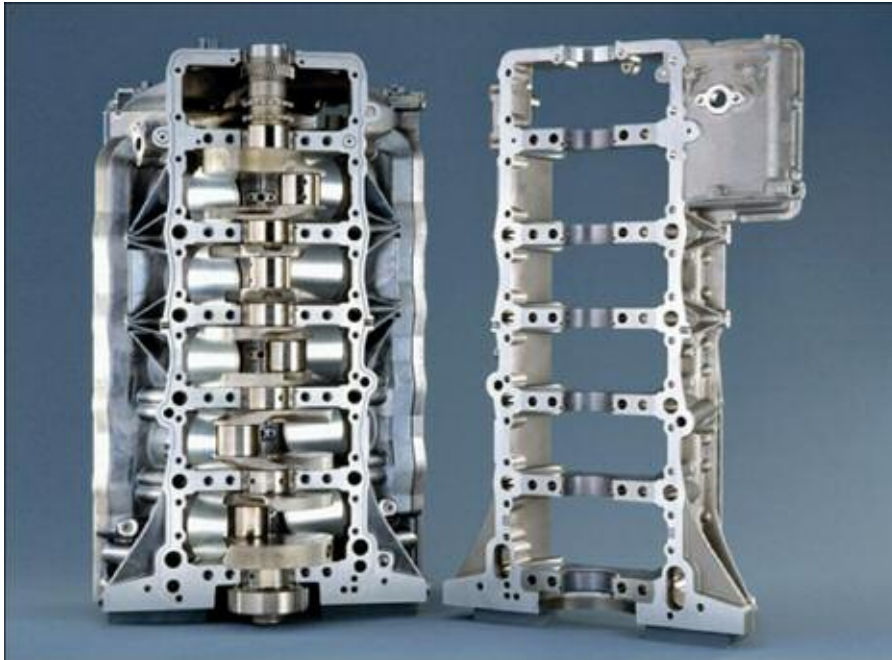

The 10 cylinder crankcase uses the familiar Alusil construction which is split at the crankshaft centerline. The bedplate is machined together with the crankcase and is mounted to the upper section of the crankcase when the engine is assembled. This design contributes to improved torsional stiffness. Better engine acoustics are also attributed to the improved stiffness.

Some of the other benefits of the bedplate include the ability to accommodate additional assemblies and to facilitate the assembly of the crankshaft main bearings.

The bedplate assembly contains cast iron bearing bridges which take up additional forces from the pistons and connecting rods. The engine serial number is stamped on the bedplate assembly.

Cutaway of S85 Engine



The bedplate is secured to the upper section of the crankcase with the main bearing bolts. The positions are fixed with fitted sleeves. Strict adherence to the bolt tightening procedure is necessary to prevent engine failure.

Cutaway of S85 Engine

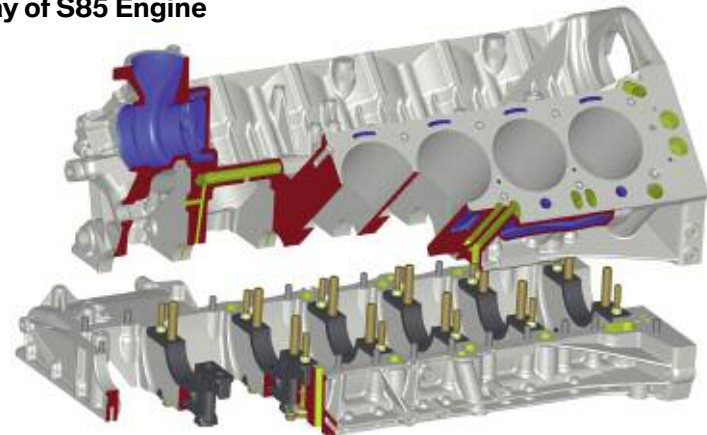

Bedplate Sealing

As with the N52 engine, the S85 uses the same technique for bedplate sealing. There is a machined groove (1) in the upper part of the crankcase. A liquid sealant is injected into the groove through ports (2) on each side of the crankcase.

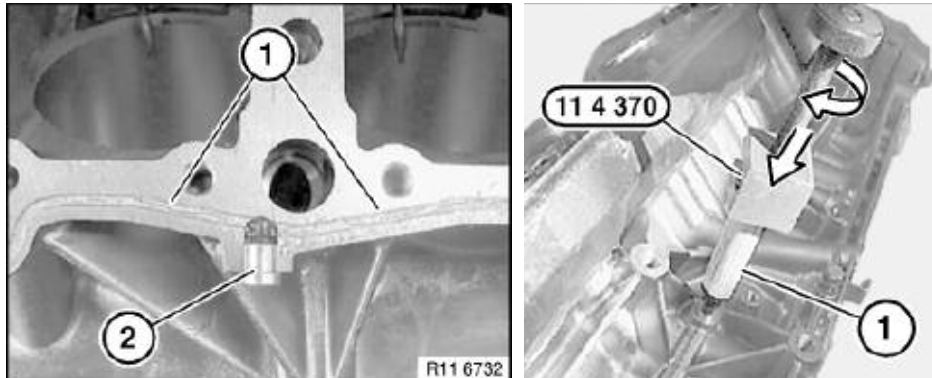

Oil Pan

The oil pan is an all aluminum one-piece design. Due to the configuration of the front subframe crossmember, the pan has a front and rear sump. The oil pan provides the mounting for the electric oil pumps and the oil lines. When removing and installing the oil pan, note the location of the oil pan bolts. There are 4 different types of bolts, each requiring a specific installation location.

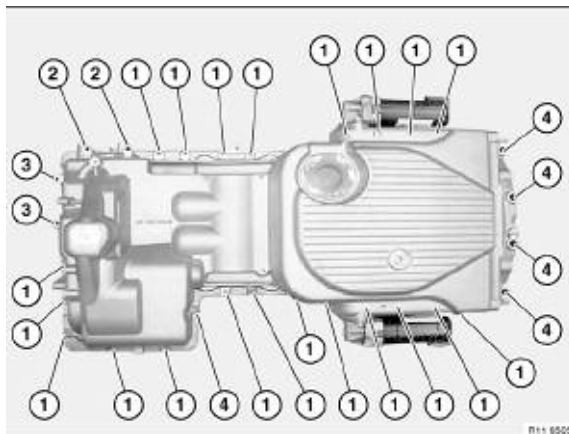

Crankshaft

The S85 crankshaft is forged steel and has 5 crankpins (journal) each offset 72 degrees apart. The crankshaft is also “nitro-carburized” for increased surface hardness.

The sprocket for the primary chain drive is integrally cast as part of the crankshaft. Also, the drive sprocket for that VANOS high pressure pump is bolted to the crankshaft snout.

The color codes for the main bearing classification are stamped onto the crankshaft.

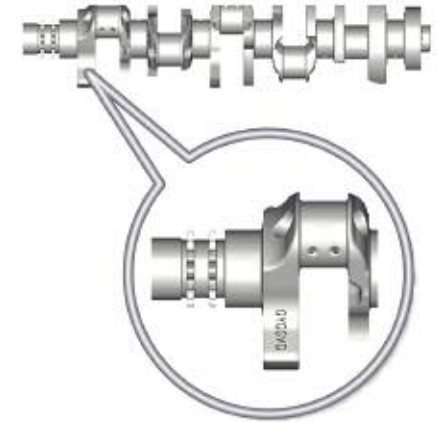

Connecting Rods

The connecting rods are forged steel and use the “cracked” configuration on the “big end”. For weight reduction, the small end of the connecting rod is trapezoidal and uses a tapered piston pin.

The connecting rods weigh 582 grams +/- 2 grams. The rods are also of asymmetrical construction which allows for a narrower connecting rod. The narrower rods contribute to the overall reduction in engine length. The rods can only be installed one way. Refer to repair instructions during installation.



Pistons

The pistons are cast from aluminum alloy. To promote the optimum friction partner with the cylinder bore, the piston skirt is coated. There is a galvanic ferrous layer at a thickness of approximately 10 microns. There is an additional tin layer of 2 microns that act as the run-in layer.

Cylinder Head and Valvetrain

The cylinder head is an aluminum one-piece design to improve overall rigidity. The idle air port and secondary air channel are integrated into the head.

The familiar 4-valve per cylinder arrangement is used on the S85. However there are some additional refinements carried over from racing applications.

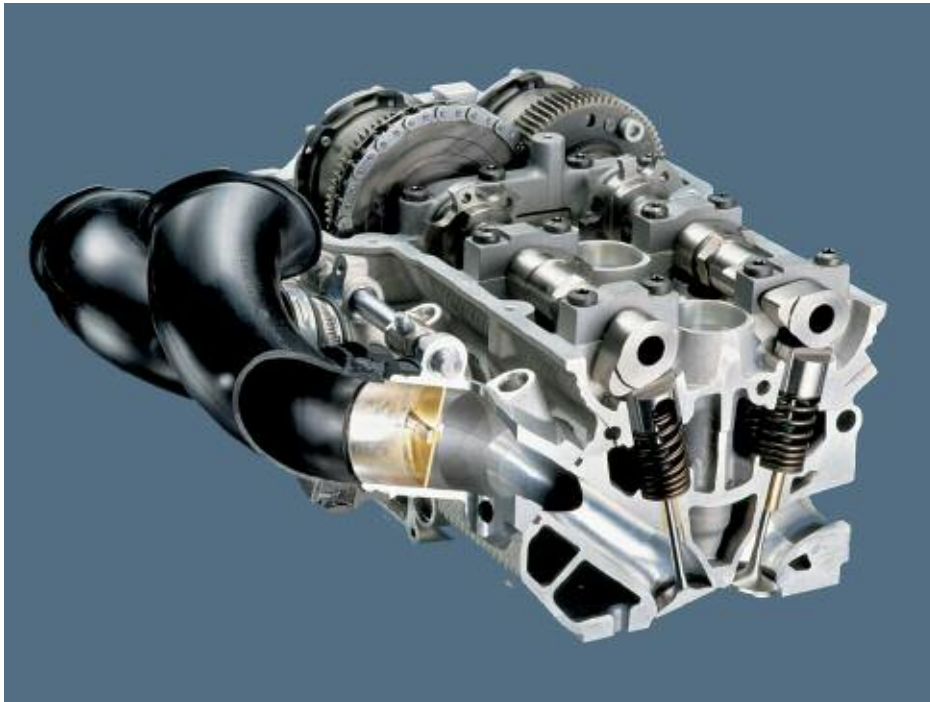

Cylinder Head Cover

The cylinder head cover is cast aluminum with provisions for mounting the ionic current control units as well as the camshaft sensors and components for the crankcase ventilation system.

Valves

Both the intake and exhaust valves are designed as solid valves with a 5mm stem diameter. The reduced stem diameter not only reduces weight, but also improves airflow qualities.

The intake valve is a one-piece design made from a steel alloy (X45CrSi9-3). In contrast, the exhaust valve is a two piece design. The stem is made from the same steel alloy as the intake valve and is friction welded to the valve head, which is made from different alloy (NiCr20TiAl).



Note: It is important to note that the valve guides are not replaceable and the cylinder head cannot be machined.

Valve Springs

The valve springs are the conical design familiar from past engine designs.



Valve Keepers

The valve keepers are a single row design rather than the three row design. The single row design is a “clamping type” which prevent the valve from turning during engine operation. The valve turning method is not needed due to the clean efficient combustion and close production tolerances.

The single row keeper is also 50% lighter than the three row design. In addition, the single row design provides less stress on the 5mm valve stems for increased reliability.



Hydraulic Valve Actuators (HVA)

The HVA assemblies are differently configured from past designs to save weight and improve the frictional characteristics. The new tappet design is referred to as the “box” type tappet. This style of tappet has been used in racing applications. The box tappet does not rotate in the cylinder head, therefore a groove is milled to prevent rotation. A corresponding “anti-torsion” pin is part of the tappet.

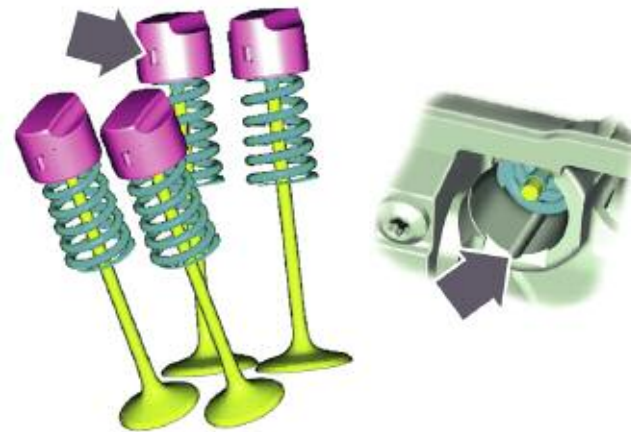

Camshaft

The camshaft is a “hollow chill” casting (GGG60). In contrast to previous designs, the camshaft sensor trigger wheel is cast as one piece with the camshaft. An M12X1 thread is integrated into the camshaft for the VANOS gear mounting.



Camshaft Drive

The primary camshaft drive is provided by two timing chains to drive the intake camshafts (one chain for each intake camshaft). The exhaust camshafts are driven by a “gear-to-gear” connection between the intake camshaft sprocket and the exhaust camshaft sprocket.

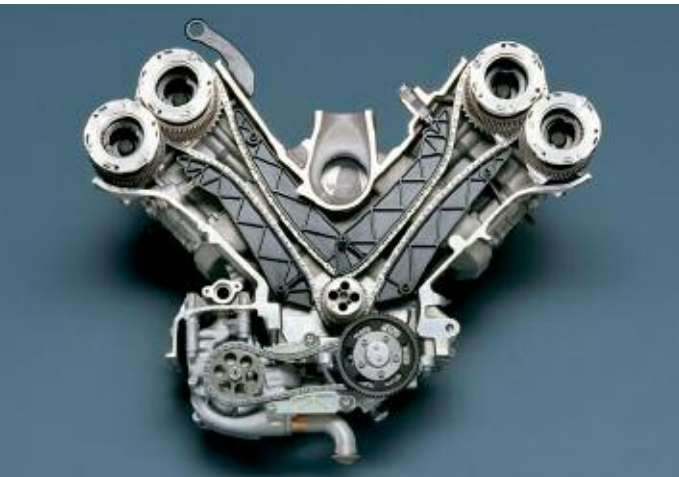

VANOS

The VANOS system on the S85 is carried over from previous “M-engine” designs with some minor changes. The adjustment range of the intake camshafts is 60 degrees of crankshaft angle and the exhaust camshaft can be adjusted up to 37 degrees (crankshaft).

The S85 VANOS system is operated on the “high-pressure” concept which uses up to 115 bar for VANOS operation.

The VANOS high pressure pump is driven directly from the crankshaft via a gear-to-gear connection. The pressurized oil is routed from the pump via two delivery lines to the two VANOS units. A “T-connection” provides high pressure oil to the pressure accumulator. (See arrow below)

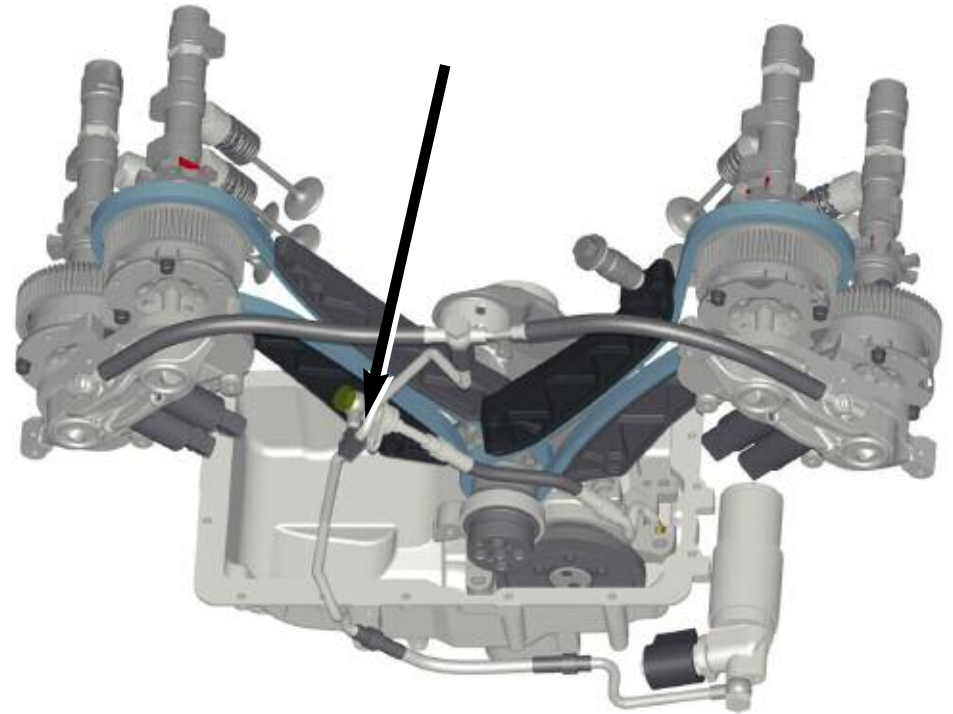

Vanos Hydraulic Diagram

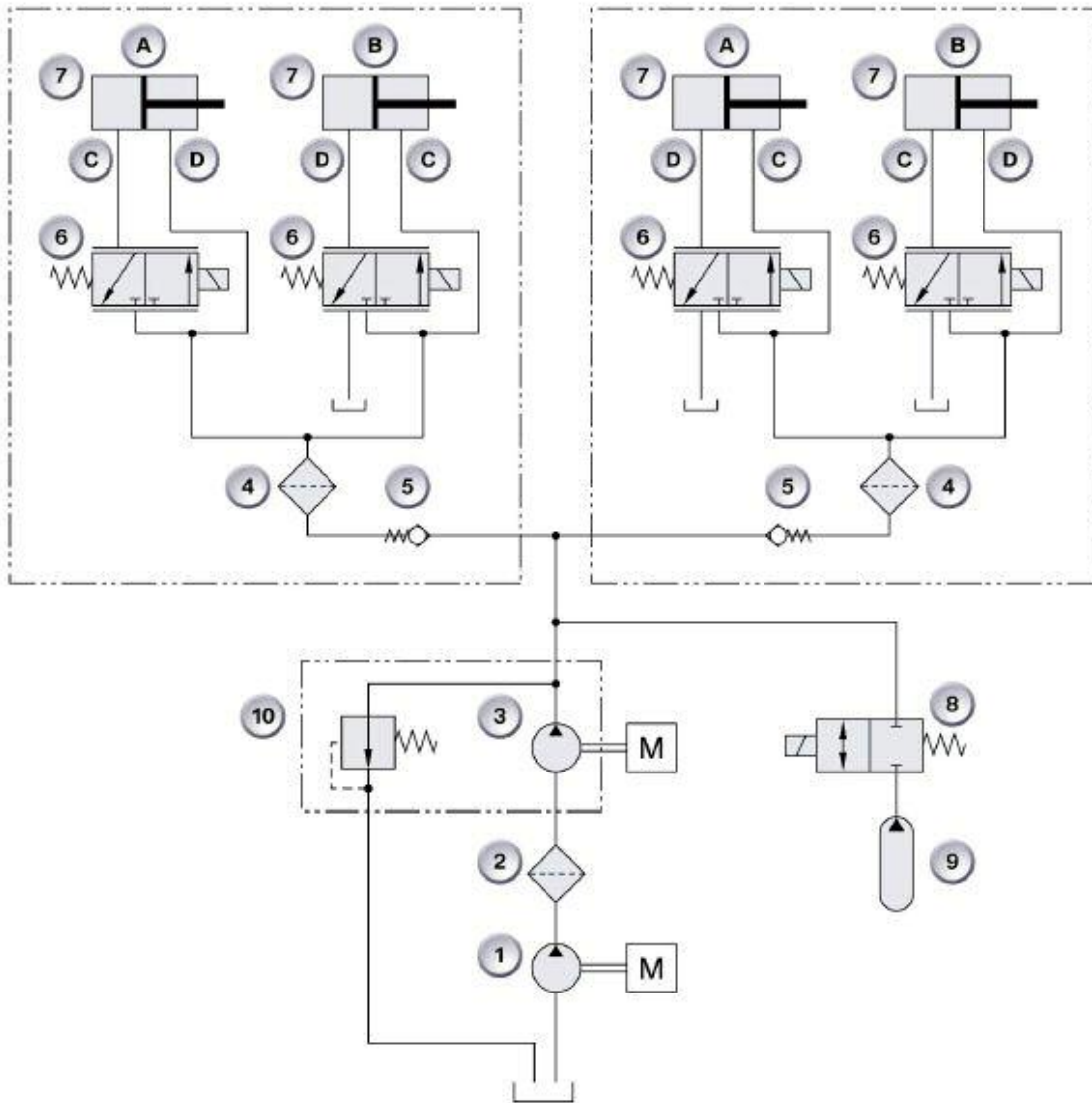

Index	Explanation
A	Exhaust
B	Intake
C	Advance
D	Retard
1	Engine oil pump (1-5 bar)
2	Filter (80 micron)
3	High pressure pump (115 bar - HDP)
4	Filter (50 micron)
5	Check valve (optional)
6	Proportional valve
7	Adjustment piston, pressure accumulator
8	Pressure accumulator shut-off valve
9	Pressure accumulator
10	Pressure relief valve HDP VANOS hydraulic units

VANOS Actuators

Separate adjustment units are provided for each cylinder bank for the purpose of adjusting the VANOS gear mechanism. These adjustment units are known as the actuators. The VANOS high pressure pump supplies them with oil under high pressure.

Since the exhaust camshaft is driven via a gear-to-gear connection, the intake and exhaust camshaft rotate in opposing directions, the intake is adjusted towards advance and the exhaust towards retard when the plunger extends. (See arrows.)

The adjustment pistons are designed as double-acting cylinders and differ with regard to the adjustment range for the intake and exhaust camshafts.

The stroke range on the exhaust side of maximum 14.25 mm corresponds to 18.5° camshaft angle (37° crankshaft angle). The stroke on the intake side of maximum 25.25 mm corresponds to 30° camshaft angle (60° crankshaft angle).

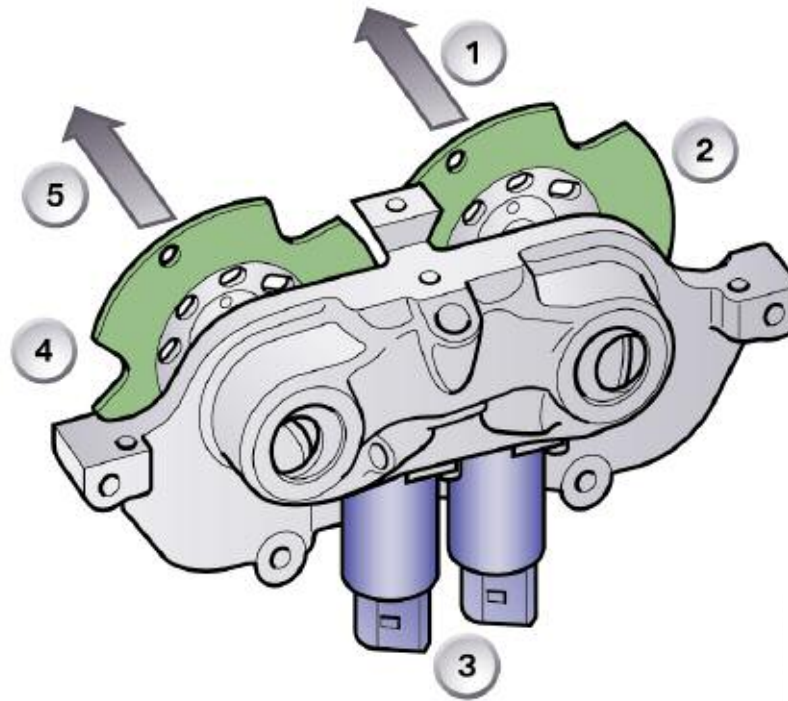

Index	Explanation	Index	Explanation
1	Adjustment direction, advance	4	Exhaust
2	Intake	5	Adjustment direction, retard
3	Plug contacts for solenoid valves		

When extended into the two piston chambers, the adjustment pistons are subject to a system pressure of 115 bar. They therefore extend only due to the different piston surface areas.

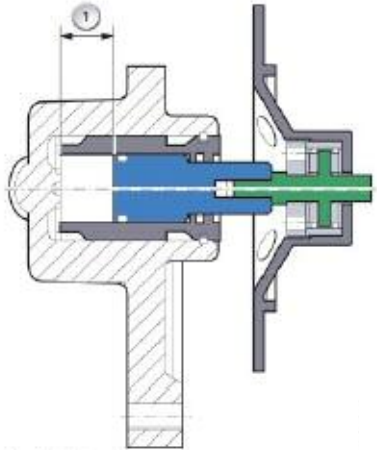

Stroke range of adjustment piston

The oil from the small piston chamber is transferred into the high pressure circuit. The proportional valve must be fully actuated in order to extend the adjustment piston.

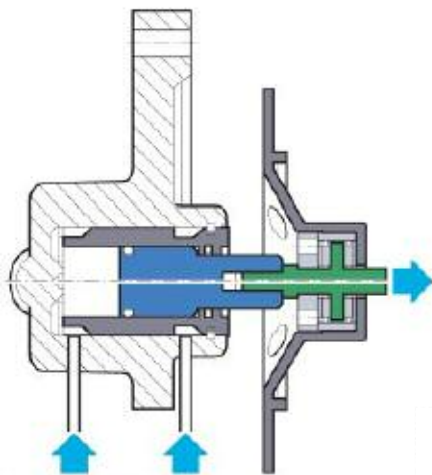

Adjustment piston extending

The holding function and piston retraction are achieved by reducing the oil feed on the side with the largest piston surface area by partly actuating the proportional valve.

The reduced oil feed decreases the oil pressure, thus initiating a change in the forces exerted on the adjustment pistons.

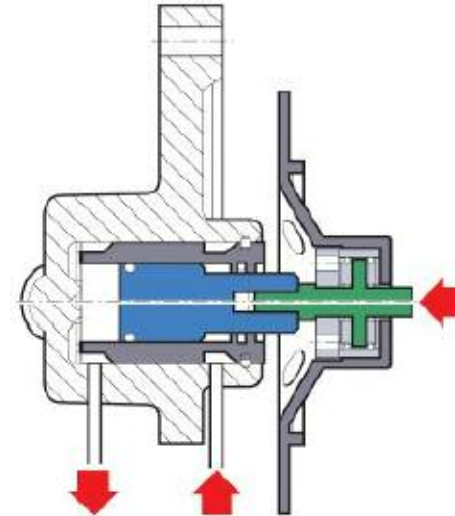

Adjustment piston retracting

The retraction movement of the adjustment pistons is supported by the camshafts as they push back the spline shafts in the hydraulic units due to the helical gearing in the VANOS gear mechanism.

VANOS Gear Mechanism

The VANOS gear mechanism (transmission) connects the crankshaft with the intake camshafts via a chain sprocket. The intake VANOS gear mechanism also provides the drive mechanism for the exhaust camshaft via a gear-to-gear connection. The gear mechanism also permits "torsion" of the camshafts. The gear mechanisms for the intake and exhaust sides differ in terms of the exterior structure of the gear and chain drive while the adjustment mechanism on the inner side is identical.

The gear mechanism is driven by the drive gearwheel that interacts with the helical gearing on the inner sleeve. The threaded connections for the gearing connects the inner sleeve to the outer sleeve. With (wide) helical gearing, the inner sleeve acts on the bearing assembly for the drive gearwheel that is firmly secured to the camshaft with the central bolt.

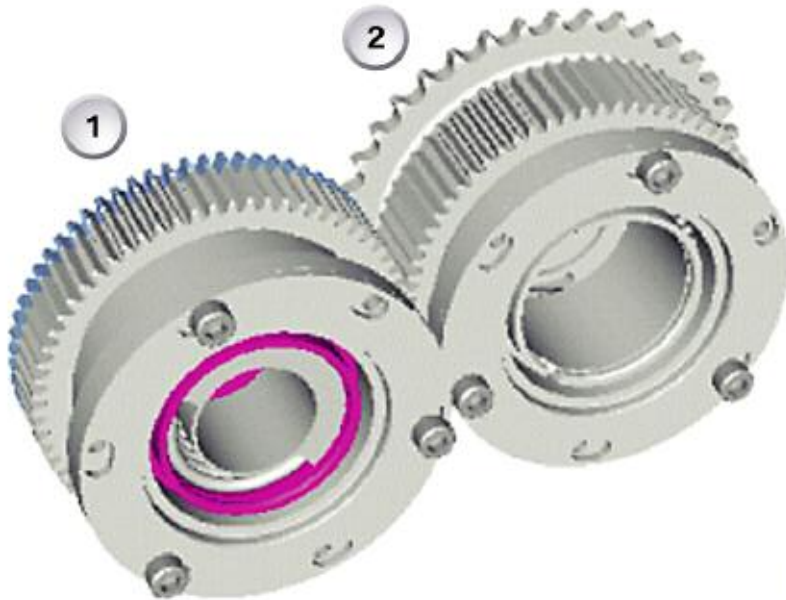

Index	Explanation	Index	Explanation
1	Exhaust	2	Intake

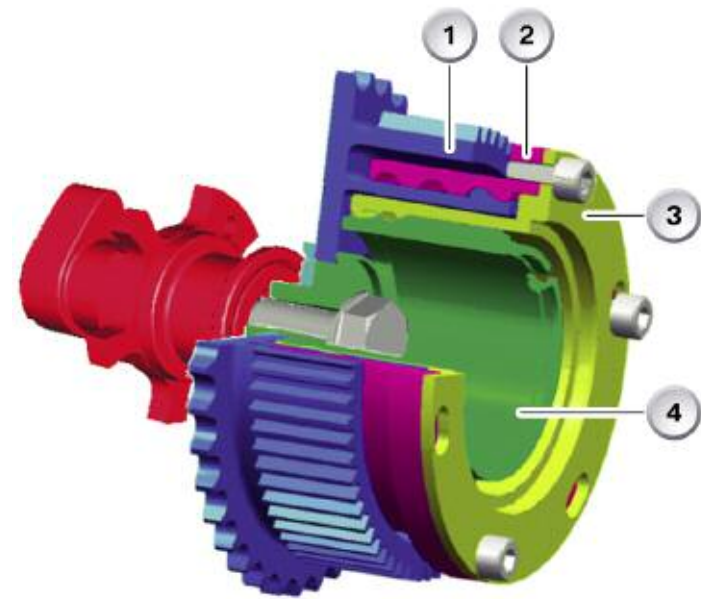

Index	Explanation	Index	Explanation
1	Drive gearwheel assembly	3	Outer sleeve
2	Inner sleeve	4	Bearing for drive gearwheel

The actuator (adjustment unit) is connected to the outer and inner sleeve by the screw connection of the gear mechanism. During adjustment, the inner sleeve and outer sleeve are pulled out of and pushed into the gear mechanism.

The inner sleeve is turned by the helical gearing on the "fixed" drive gearwheel (timing chain drive). Due to the non-positive screw connection of the outer sleeve, this sleeve also turns. In connection with a further helical gear, the outer sleeve now turns the bearing for the drive gearwheel and in turn the camshaft connected with the central bolt.

The gear units are mounted in their base position, i.e. pulled apart. The camshafts are adjusted when the gear units are pushed together. The drive gearwheel and bearing for the drive gearwheel are connected by a torsion spring to assist the return movement.

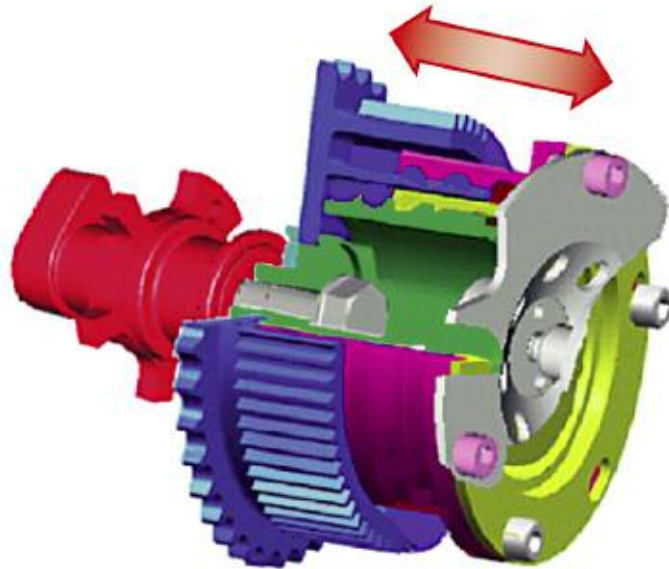

Intake gear mechanism adjustment direction

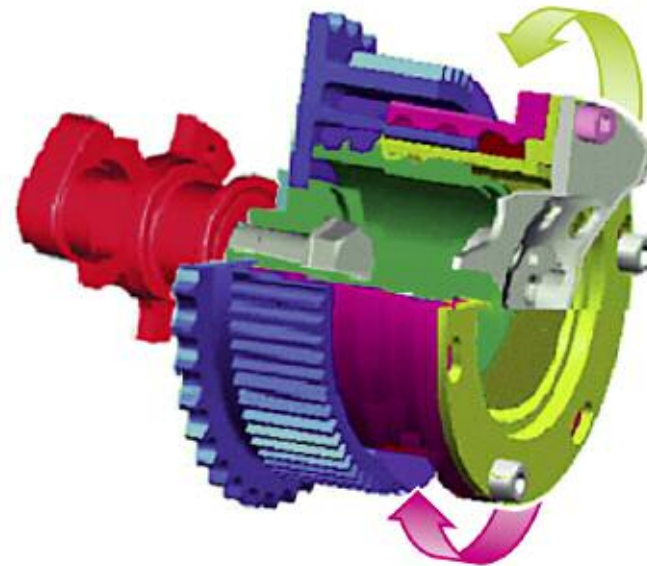

Direction of rotation during adjustment

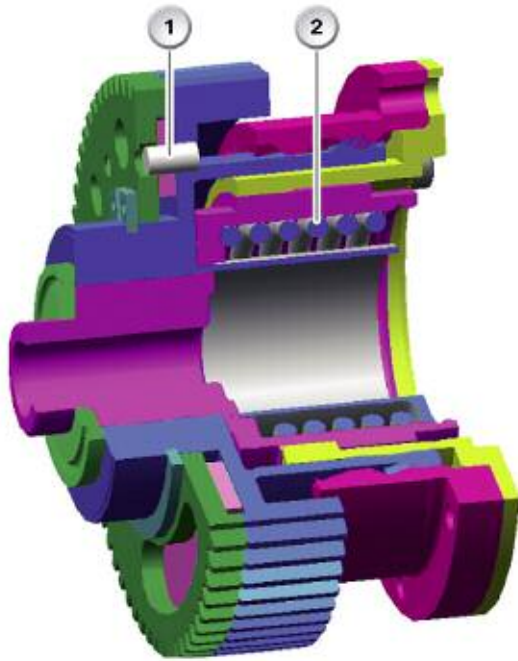

The mounting screws for the gear mechanism are tightened only lightly when assembling the actuators. As a result, no force is transmitted from the outer sleeve to the inner sleeve when sliding the actuators onto the cylinder head (to facilitate the sliding movement of the gear unit). Due to the "fixed" drive gearwheel, the outer sleeve turns in the direction of engine rotation. At the same time the "fixed" bearing for the drive gearwheel turns the inner sleeve opposite the direction of engine rotation.

The exhaust camshaft is driven by the intake camshaft in connection with a gear drive mechanism. The drive gearwheel is split in two in order to avoid gearing noises caused by a change in the driving tooth profile in connection with a change in load. A disc spring turns the two halves of the gearwheel in opposing directions (functional principle similar to dual-mass flywheel) so that both tooth profiles of the exhaust gearwheel always rest on the intake gearwheel under all load conditions.

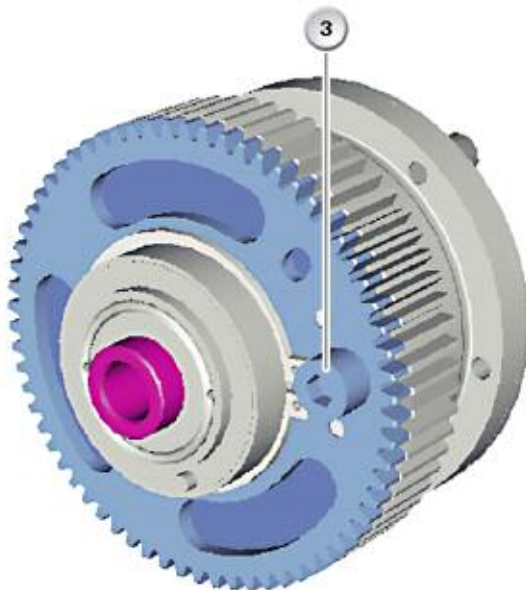

Index	Explanation	Index	Explanation
1	Annular spring	3	Lock screw
2	Torsion spring		

VANOS High Pressure Pump

The high pressure pump is designed as a radial piston pump with five pump plungers. It is driven via a gear mechanism directly by the crankshaft. To avoid gearing noise, when mounting the sprocket of the high pressure pump, the coated part must face towards the crankshaft without any clearance. The correct gear clearance is then established automatically by the coating scraping off.

The high pressure pump receives its oil supply from the bedplate. An 80 micron fine filter is installed in the transition hole from the bedplate to the high pressure pump. This filter has the sole purpose of holding back any impurities that may accumulate during series production and is not replaced during vehicle operation.

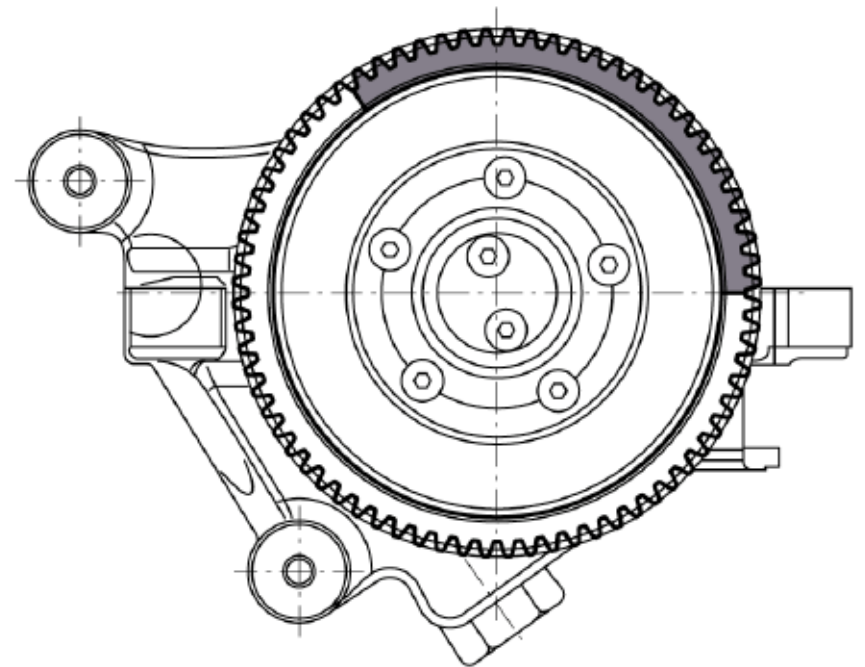

A feed valve in the high pressure pump ensures a constant supply of oil over the entire pressurized engine oil range.

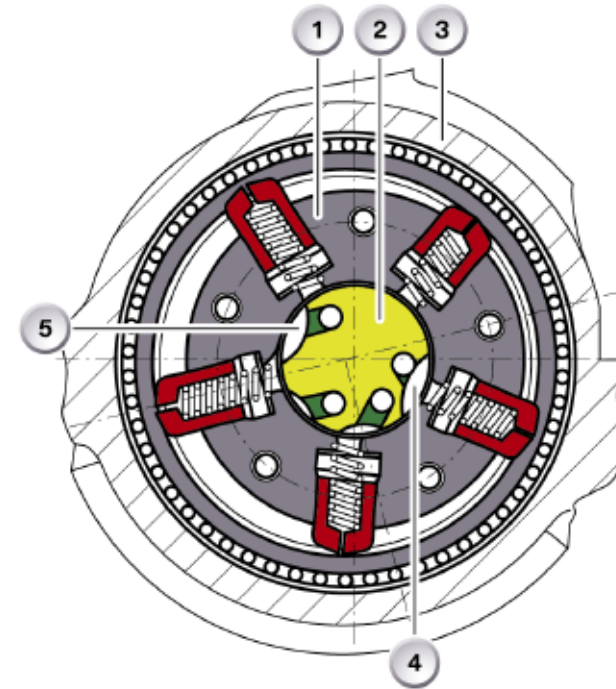
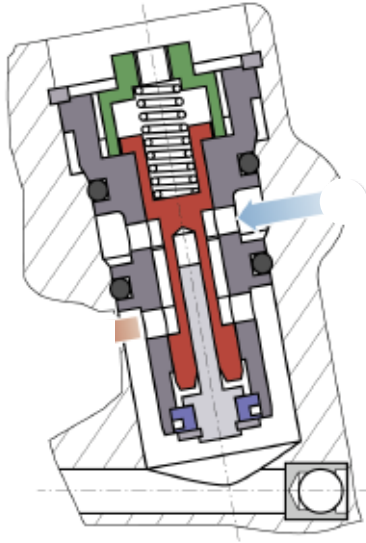

The high pressure pump consists of the fixed stator about which the rotor rotates. Five moving plungers are mounted in the rotor. The stator and rotor are installed off-center in the pump housing. The plungers are guided radially as the rotor rotates thus producing the pump stroke motion.

Index	Explanation	Index	Explanation
1	Rotor	4	Engine oil is supplied by the stator and taken up by the pistons
2	Stator	5	Engine oil is compressed and returned to the stator at 115 bar.
3	Pump housing		

The pressure relief valve integrated in the high pressure pump opens in response to pressure peaks in the high pressure system and opens up a bypass to the oil pan.

The oil pressurized at 115 bar is routed via three delivery lines to the two VANOS control units and to the pressure accumulator.

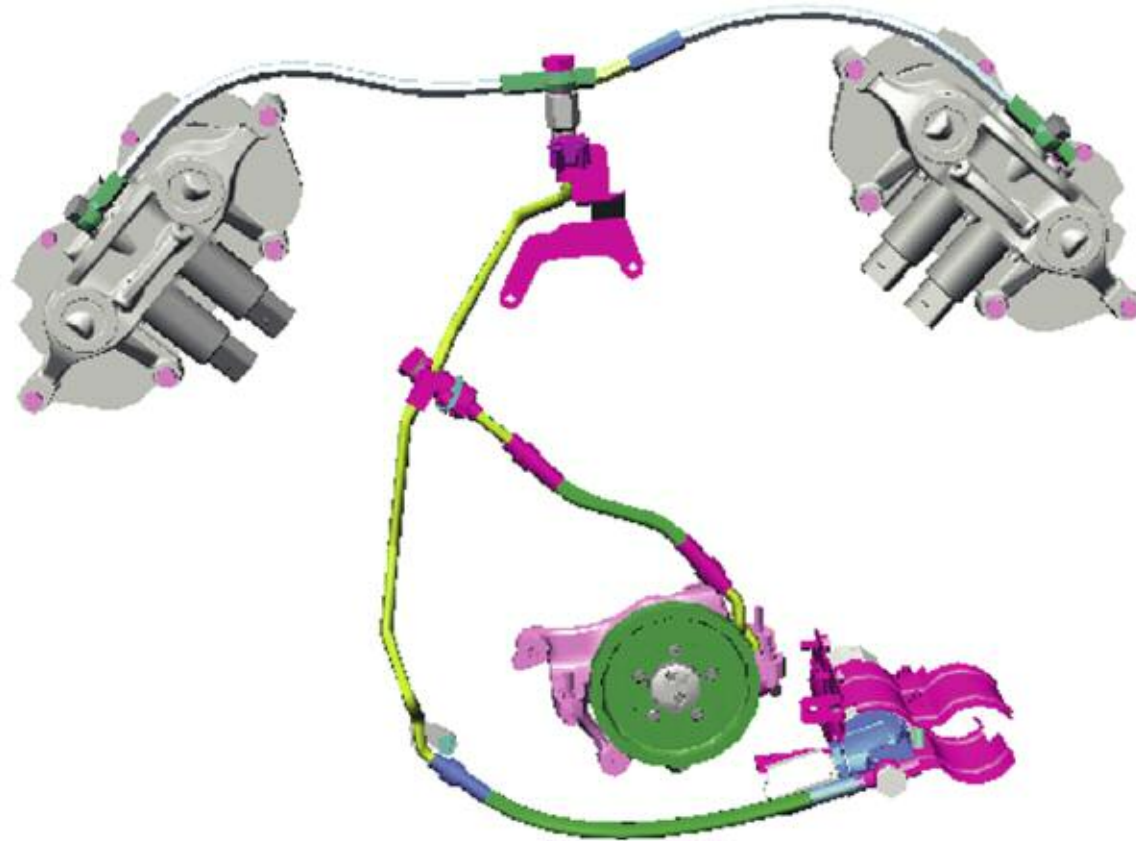

Lubrication System

The S85 is equipped with a quasi-dry sump. For this reason, a suction pump is used to pump the oil out of the oil pan in the area ahead of the rack and pinion power steering gear into the rear oil sump. From here, a controllable slide valve pump conveys the oil at a maximum pressure of 5 bar into the oil filter. A thermostat that enables the path to the engine cooler is additionally located in the oil filter head.

The oil is then routed from the oil filter into the engine. Here it is divided over three lines to the two cylinder heads and to the crankcase.

A special feature of this system are the two electrically driven oil pumps that are located on the left and right of the oil pan. The electric oil pumps start up at a transverse acceleration of 0.8 G and pump the oil from the cylinder heads which, under these centrifugal force conditions, would otherwise no longer flow back into the oil pan.

The crankcase is ventilated by a cyclone separator in the intake air manifold. The return flow line from the oil separator and the condensation return flow lines from the intake air manifolds are routed along the 6-10 cylinder bank of the crankcase into the oil sump.

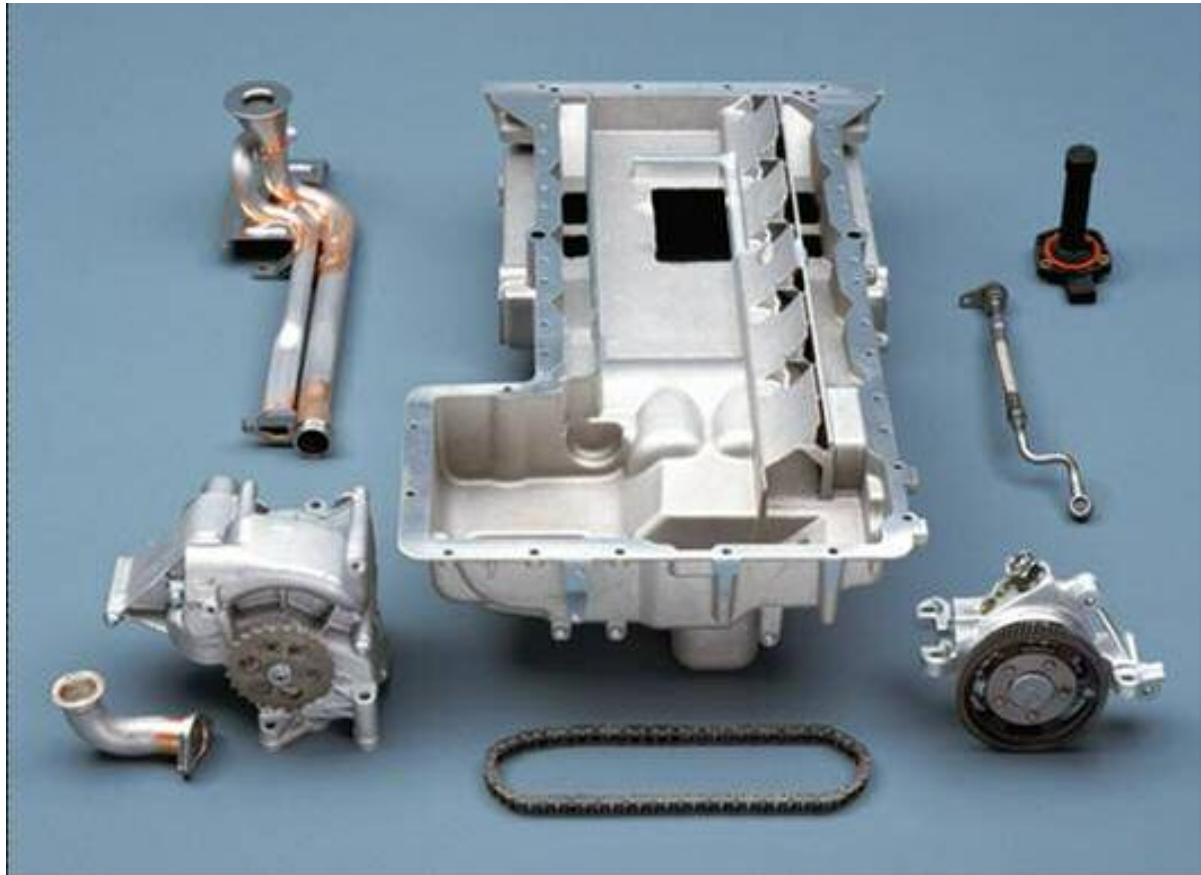

Oil Pumps

Due to the race-inspired design of the S85 engine, the lubrication system has been adapted to meet the oiling needs during all operating conditions.

The primary oil pump is driven from a chain connected to the high pressure VANOS pump (which is driven via the gear-to-gear connection with the crankshaft). The oil pump housing accommodates two oil pumps. One of the pumps is a duocentric design which pumps oil from the front oil sump to the rear oil sump. This ensures that oil is in the rear sump at all times especially during hard braking.

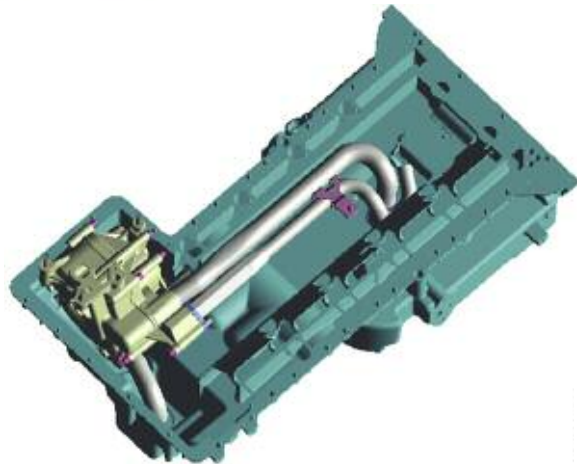
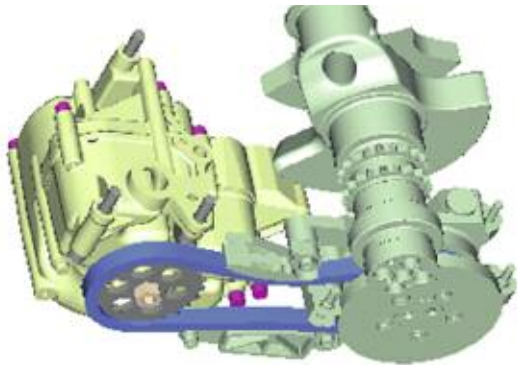

The other pump is a slide-valve design which has a variable displacement capability. The slide valve pump takes the oil from the rear sump and conveys it to the oil filter at a variable pressure of up to 5 bar.

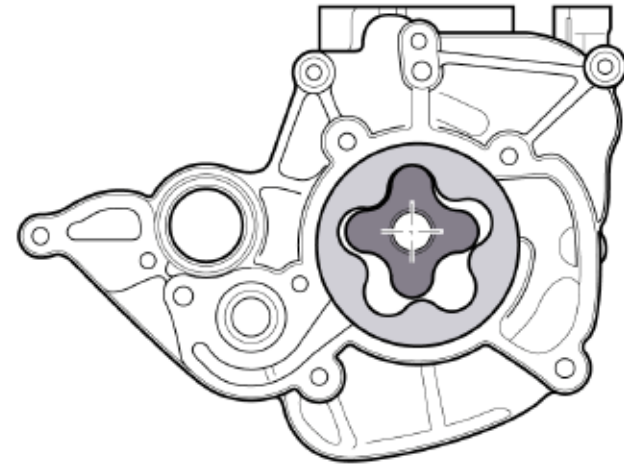

Duocentric Oil Pump

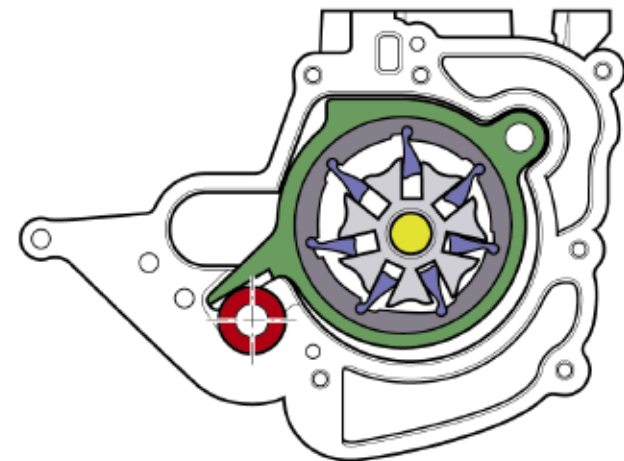

Slide Valve Oil Pump

The pump outlet is determined by the eccentricity of the pendulum-type slide valve. No oil is delivered when the pump runs centrally with respect to the rotor as all pump chambers are the same size.

The slide valve is displaced by an inclined piston. This piston is in equilibrium between the piston spring and the engine oil pressure.

The greater the engine oil pressure, the more the piston is pressed against the spring and the more the slide valve turns in the direction of 0 delivery.

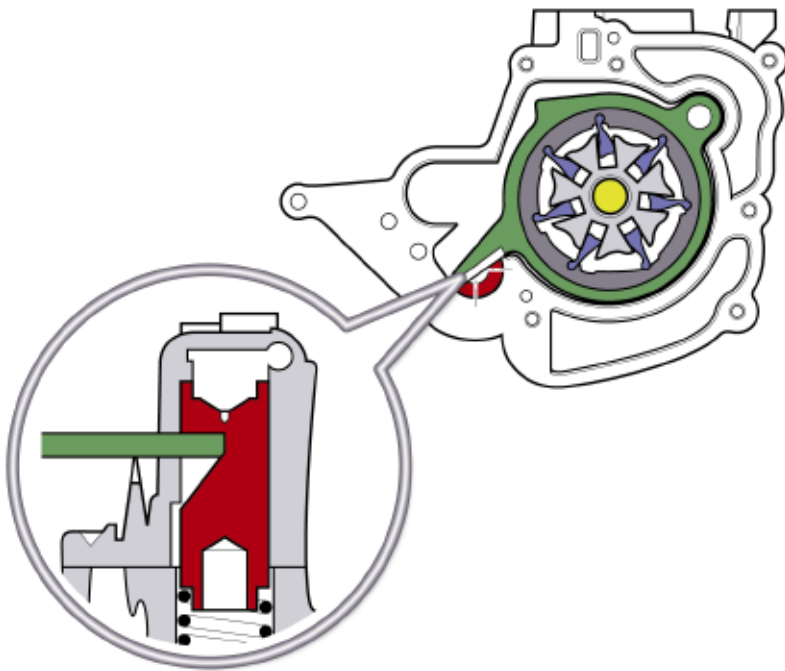

Low pressure scenario

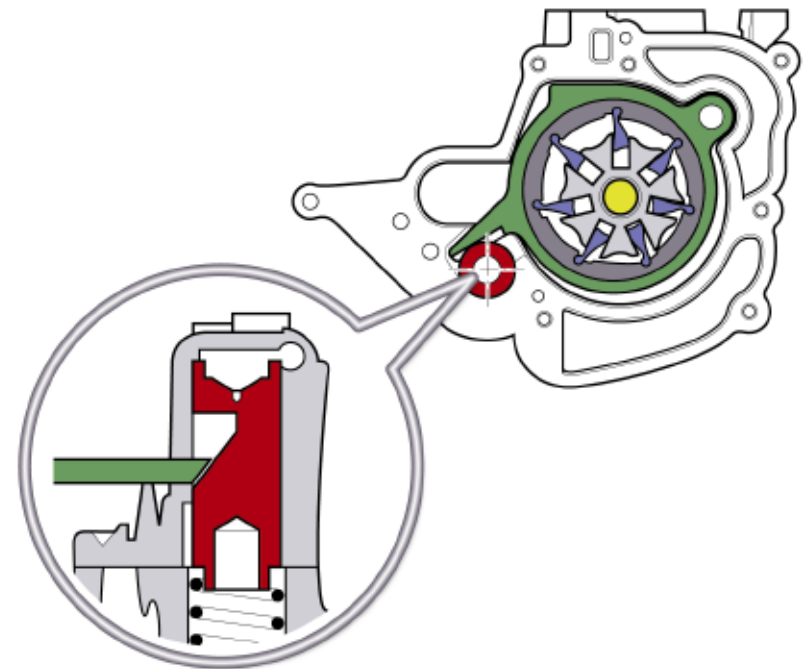

High pressure scenario

Electric Oil Pumps

When cornering at high speeds, the centrifugal force forces the engine oil into the outer cylinder head so that it can no longer flow back into the oil pan on its own.

It must therefore be pumped off by the respective oil pump and returned to the oil sump. The electric oil pumps are activated by the engine control unit which determines the cornering speed with a yaw rate sensor.

The electric oil pumps are protected by heat shields from the heat radiated from the exhaust manifolds.



Oil Spray Nozzles

Double-hook oil spray nozzles are used on the S85 for the purpose of cooling the piston crown. The oil spray nozzle is equipped with an integrated pressure control valve.

Opening pressure: 1.8 to 2.2 bar

Closing pressure: 1.3 to 1.9 bar

Oil Filter Housing

A thermostat that opens the path to the engine oil cooler is mounted in the head of the oil filter housing.

The filter housing is located behind the front bumper on the right side, near the secondary air pump.

The underbody panels must be removed during an oil service to access the oil filter.



Cooling System

The cooling system uses the cross-flow technique, however there are some changes over previous systems. For instance, each cylinder head has its own radiator feed and the coolant thermostat is located in the return flow line.

The radiator is divided into an upper and lower water tank. Coolant emerges from the Bank II (6-10) cylinder head through the upper water tank. Bank I (1-5) flows through the lower water tank.

The split cooler design makes it necessary to provide three bleeder opening and two bleeder lines to ensure adequate self-bleeding of the system.

The tap-off point for the heating system is located at the rear of the cylinder heads. The heating return line and the line to the expansion tank merge at a "T-connection" ahead of the water pump.

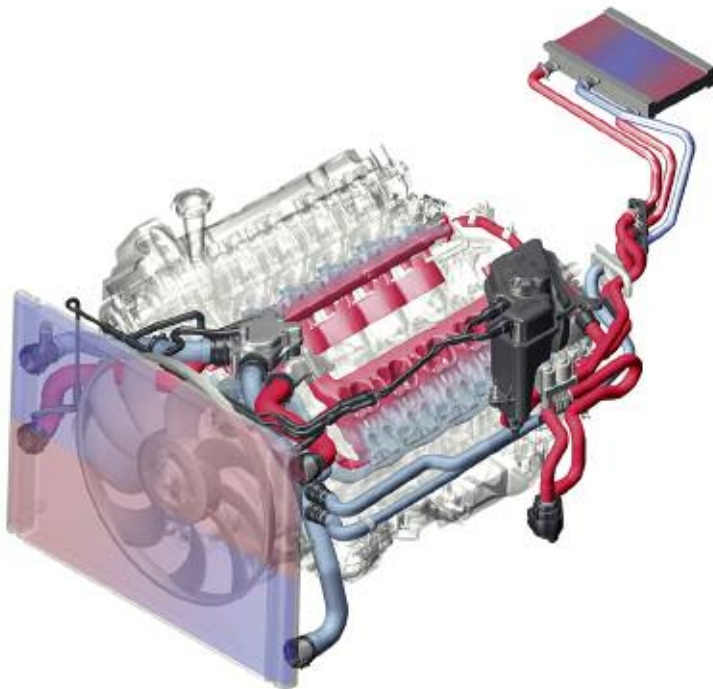

Radiator

The radiator of the S85 is divided into an upper and a lower tank. The lower tank serves the purpose of cooling the coolant from Bank I (Cyl 1-5) while the upper water tank is responsible for cooling the cylinder Bank II (Cyl 6-10).

Due to the split design, it has been possible to reduce the pressure drop in the radiator from approximately 3 bar to approximately 1.4 bar.

Thermostat

Due to the two-part cooling concept, the thermostat has been relocated to the return line. It is designed as a conventional thermostat that opens at a temperature of 79°C.

The coolant from the cylinder head enters the outlet for the radiator feed and from here it is routed both via the double o-ring carrier into the thermostat as well as into the coolant supply hoses.

Water Pump

The water pump is belt driven and it is located directly below the thermostat housing.

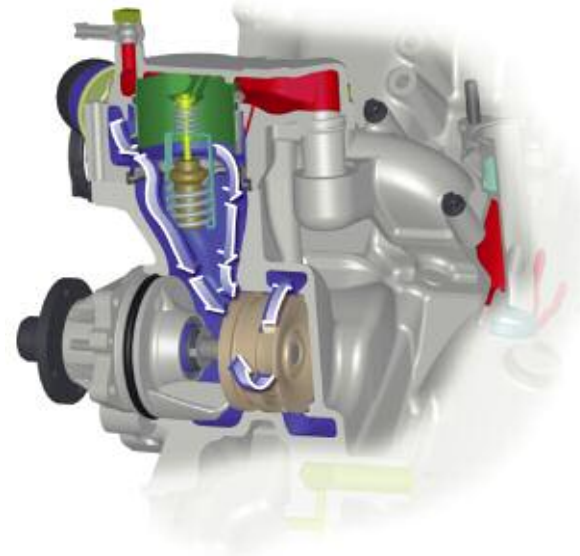

Throttle Valves

10 individual throttle valves control the air supply for the S85. The individual throttle valves of each cylinder bank are operated separately by an actuator unit and operating shaft. The actuator motors operate independently.

The throttle valves are set with respect to each other (as on S54). There are no facilities for the synchronization of the cylinder banks with respect to each other as well as for setting the full load stop. The necessary corrections are undertaken by the engine management (see section entitled Engine Management MS S65).



Idle Control

The idle speed is controlled by two idle speed actuators that route the intake air from the intake air manifolds directly into the idle air port of the respective cylinder head. Each cylinder bank is controlled individually.

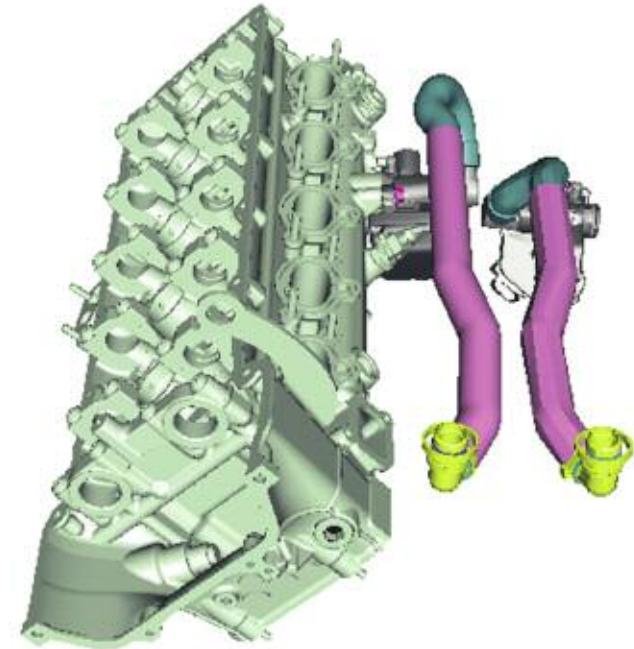

Secondary Air System

In order to comply with LEV II standards, the S85 uses a secondary air system. The secondary air system helps reduce HC emissions during the cold start period. The catalyst warm-up time is also reduced.

The secondary air is injected into the exhaust ports via pressure controlled diaphragm valves on the cylinder heads. The air from the secondary air pump is routed through channels in the cylinder heads.

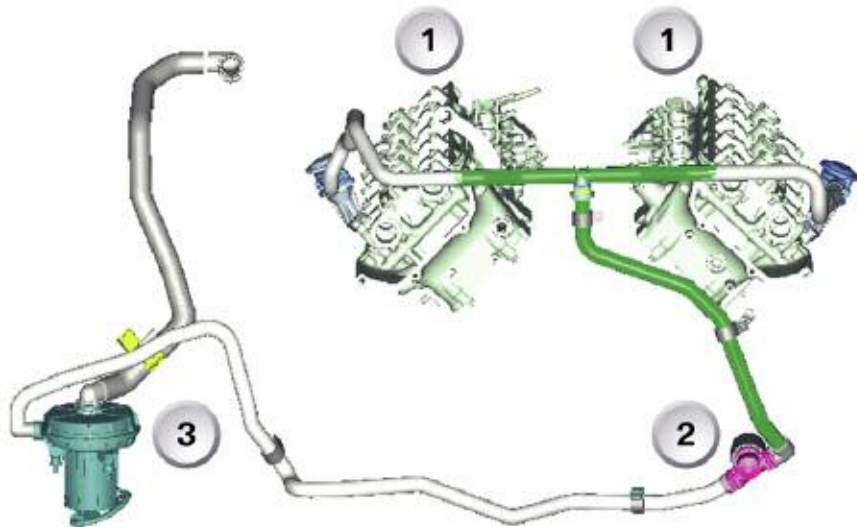

Index	Explanation	Index	Explanation
1	Diaphragm valve	3	Secondary air pump
2	Hose junction		

Exhaust System

The S85 is equipped with stainless steel exhaust manifolds. The manifolds are “hydroformed” and feature equal length tubes with a wall thickness of 0.8 mm. The tubes are configured as a 5-into-1 design with one “near-engine” catalyst per cylinder bank.

There are 2 pre-catalyst oxygen sensors for mixture control which are Bosch LSU 4.9. The two post-catalyst O2 sensors are Bosch LSF25.

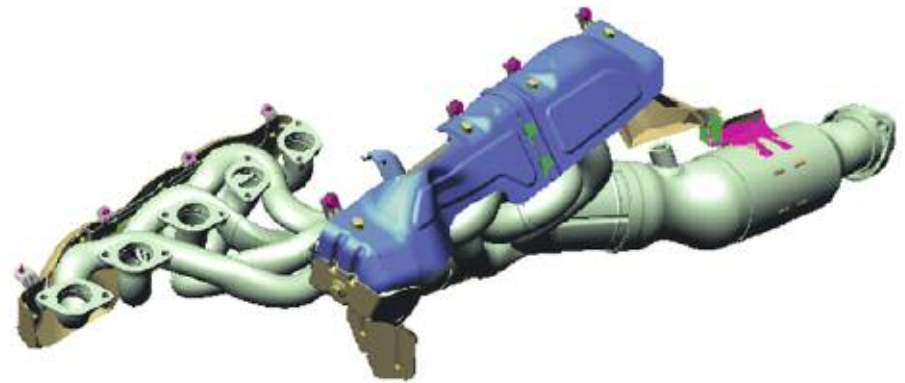



Classroom Exercise - Review Questions

1. Where are the color codes for the main bearing classification?

2. What is unique about the valve and valve keepers?

3. What are the advantages of a “box type” tappet?

4. What is unique about the camshaft drive mechanisms?

5. What drives the VANOS high pressure pump?



Classroom Exercise - Review Questions

6. Describe the oiling system on the S85: (i.e. how many pumps, what are the functions of the oil pumps etc.)

7. Where is the oil filter located?

8. What is unique about the cooling system?

9. Describe the construction of the crankcase:

10. What is meant by an “asymmetrical” connecting rod?



Workshop Exercise - Engine Disassembly

Using the instructor designated S85 engine trainer, remove the left and right intake air manifolds (plenum). Remove plastic trim covers from the cylinder head covers. Remove ignition coils and ionic current control units. Then proceed to remove **both** cylinder head covers using proper repair procedures.

What should be noted regarding the spark plug tubes?

What is the purpose of the ground strap between the cylinder head cover and the engine block?

Proceed and remove VANOS high pressure hoses and the VANOS pressure accumulator. (Do not remove internal VANOS high pressure hose)

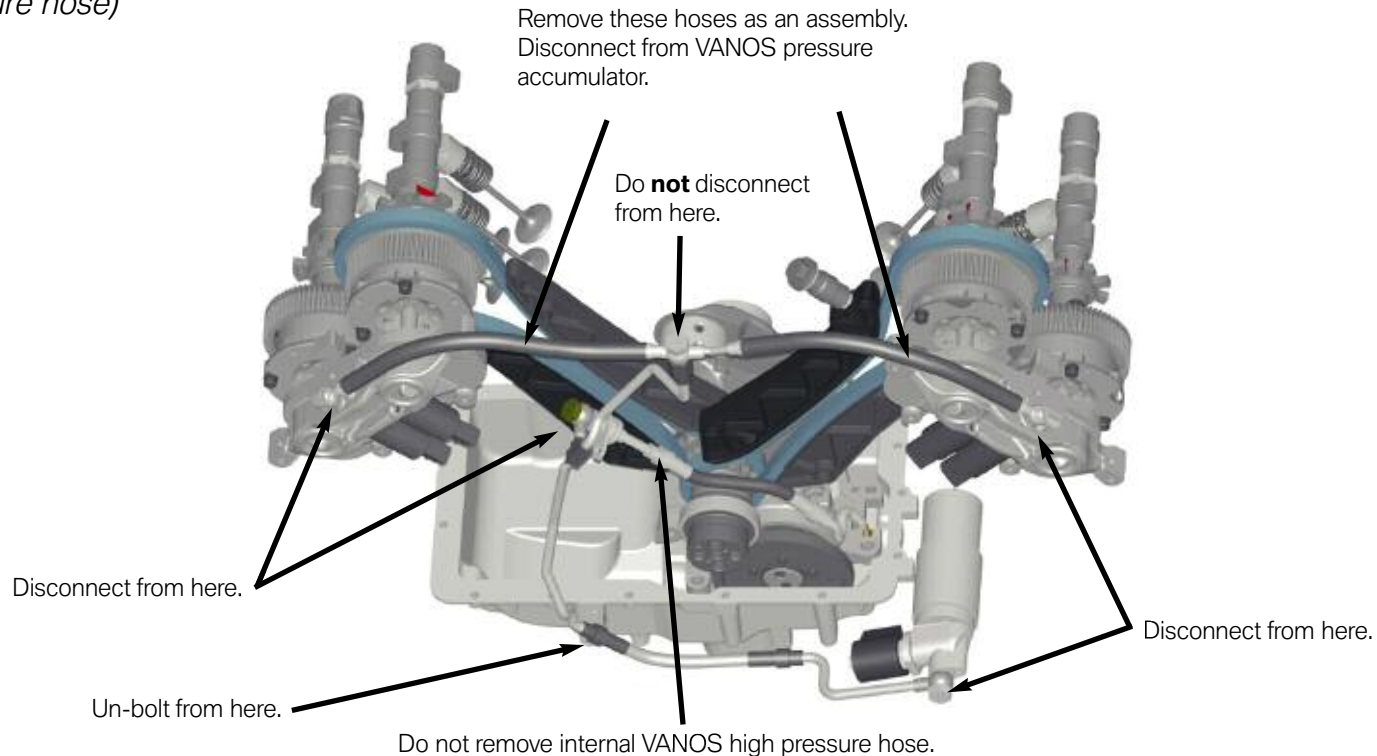



Workshop Exercise - Engine Disassembly

Invert engine on stand to remove oil pan. Pay close attention to bolt arrangement.

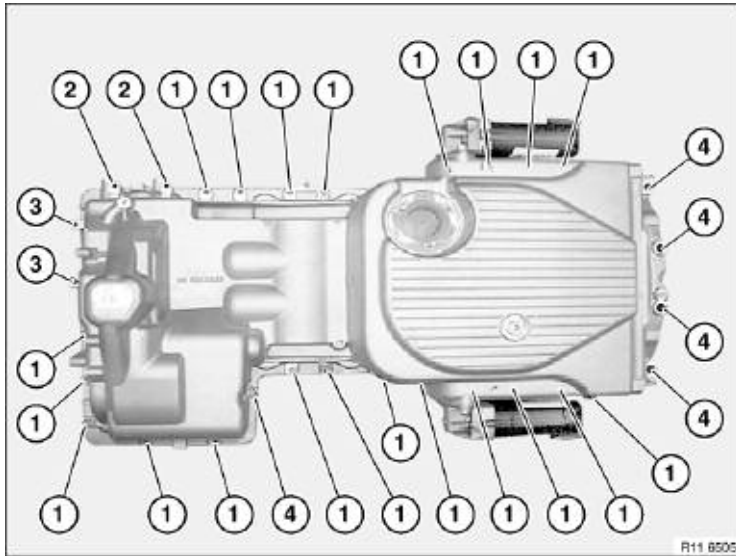

Once oil pan removal is complete, remove engine oil pump and VANOS high pressure pump.

What is the purpose of the shims under the VANOS high pressure pump?

What is the specification for VANOS pump gear backlash?

Complete chart below by filling in oil pan bolt descriptions:

Bolt #	Bolt Description (type and amount)
1	
2	
3	
4	



Workshop Exercise - Engine Disassembly

Invert engine to upright position and prepare to CHECK camshaft timing.

Rotate engine to #1 cylinder at TDC (on compression stroke). Check to see if the numbers on the camshaft (dihedron) are facing upwards.

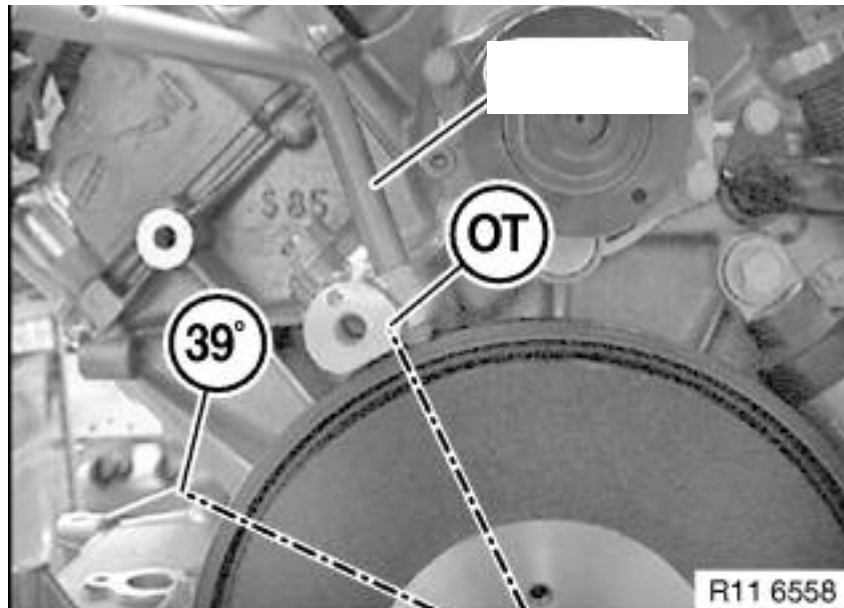

Lock engine in place at “OT” position using special tool.

Fill in the special tool number in space provided above.

Proceed to check the INTAKE camshaft timing using special tools.

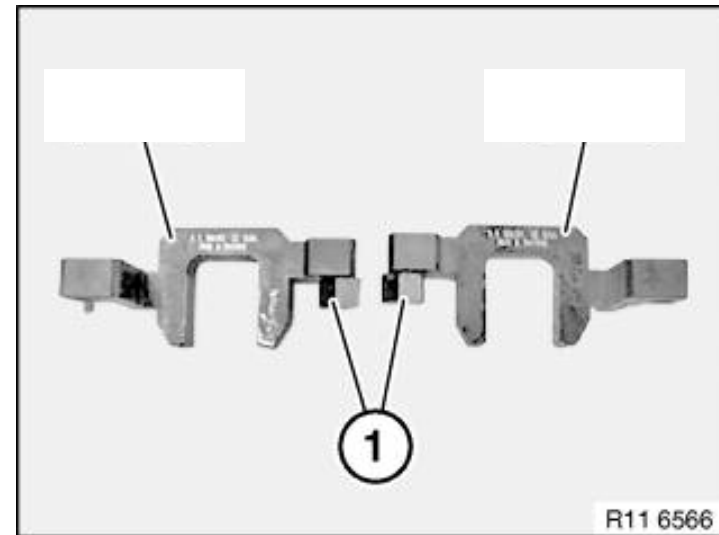

Write the part numbers in the spaces provided for the special tools shown above.

In the above illustration, what is the purpose of the spacers (1)?



Workshop Exercise - Engine Disassembly

*Rotate the engine to the 39 degree position and lock in place with special tool.
Check the EXHAUST camshaft using the special tools.*

When checking the camshaft timing (intake and exhaust), what is the maximum allowable protrusion of the special tool?

After checking the camshaft timing, proceed with removal of BOTH VANOS actuating units. Pay special attention to the removal procedure.

Do NOT loosen bolts with washers or the cam timing will be affected (if the engine is rotated).

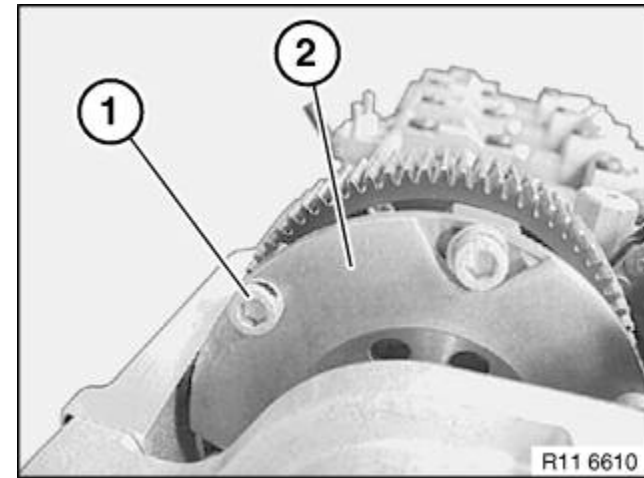
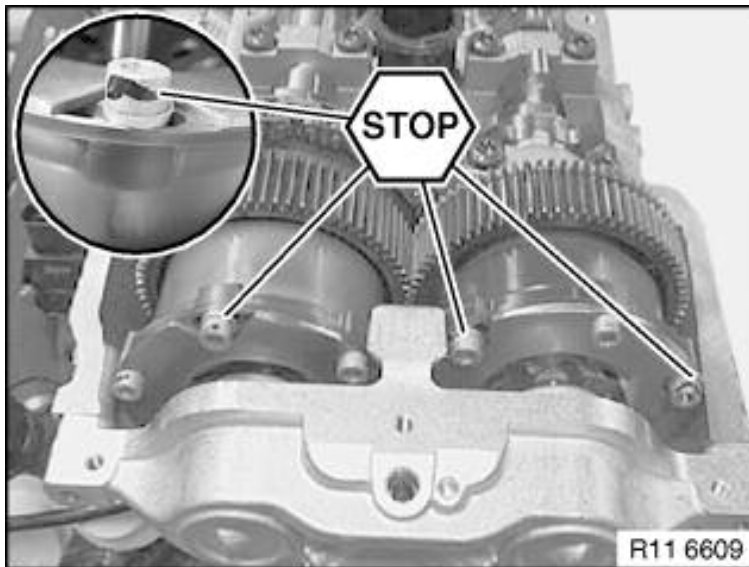

Remove 6 bolts (reference #1 on graphic) on each VANOS adjusting unit, rotate engine to access all bolts on both banks. Proceed with removal of both VANOS adjusting units as per repair instructions.

Once complete, return the engine to the #1 TDC position and proceed with removal of the bank I cylinder head (cyl 1-5).

Are the VANOS adjusting units bank specific? (Can they be swapped from bank to bank?) Why or why not?



Workshop Exercise - Engine Disassembly

Remove both intake and exhaust VANOS gear (transmission) and both camshafts to facilitate cylinder head removal.

Install all necessary special tools to remove both VANOS gears.

Install special tools as shown above, write correct tool numbers in spaces provided. Be sure to fully tighten all bolts (see 2 below).

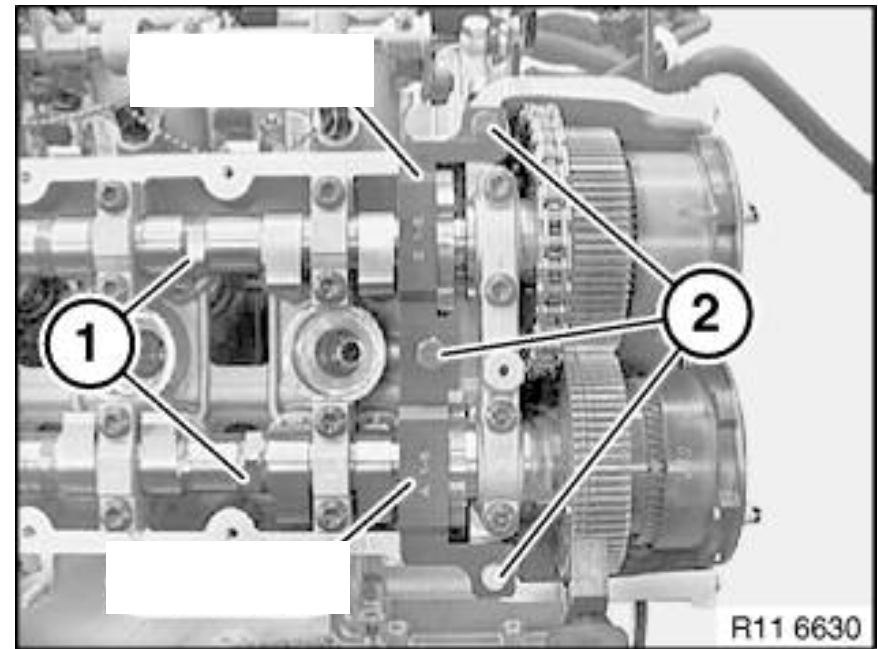
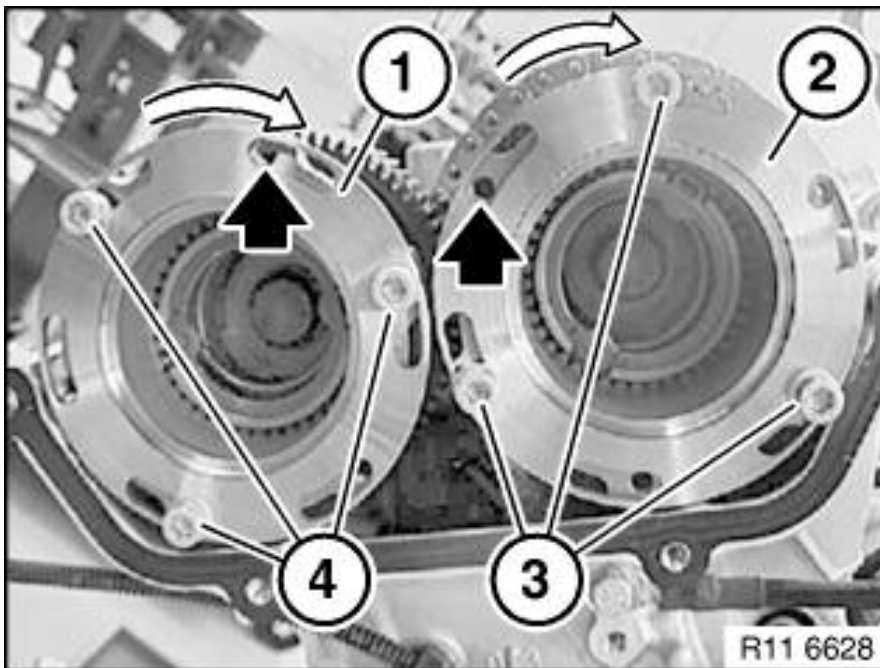

Loosen bolts (3 and 4) but do not remove. Rotate inner sleeve of VANOS gear to the left most stop (refer to graphic above 1 and 2). Re-tighten bolts (3 and 4) to approximately 5 Nm.



Workshop Exercise - Engine Disassembly

Install special tools as shown. Remove the right side chain tensioner and the bolt for the chain rail (on the cylinder head only). Fill in special tool numbers in the spaces provided below.

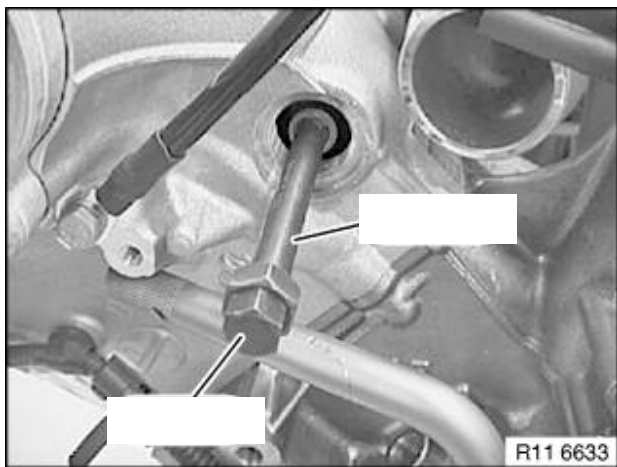
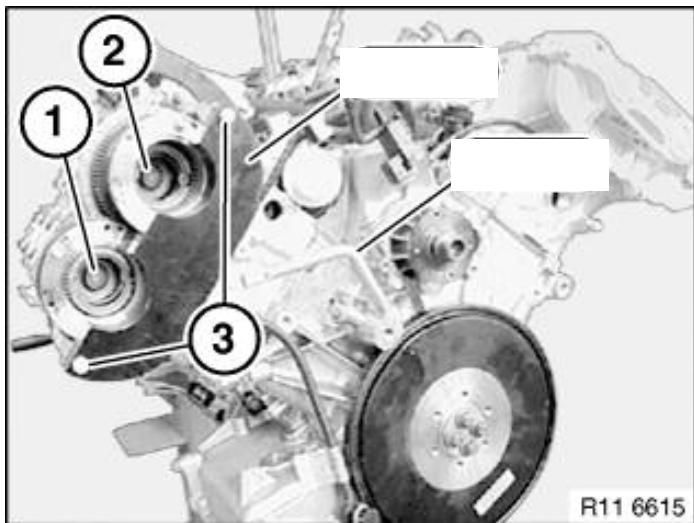

Install M8 X18mm lock bolt (2) on the exhaust VANOS gear as shown below. Tighten fully to prevent slippage of split gear mechanism (1 and 3).

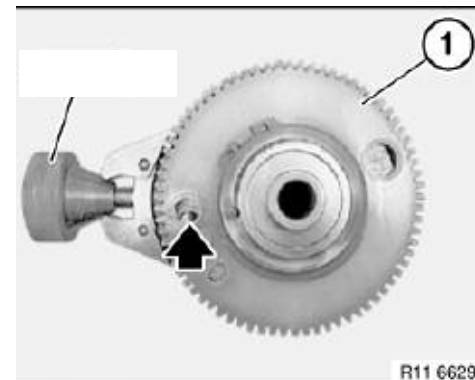
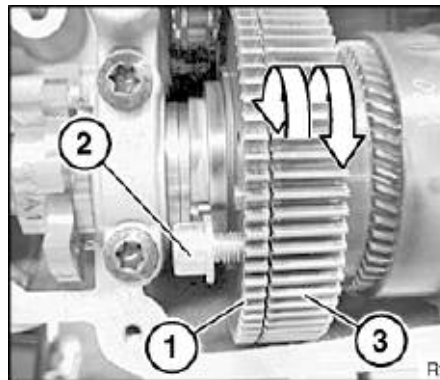

What is the purpose of the M8 x 18mm lock bolt?

What is the purpose of the special tool shown above (#1 on right)? Record the part number of the tool in the space provided.



Workshop Exercise - Engine Disassembly

Remove both central bolts on the intake and exhaust VANOS gears.

Remove exhaust VANOS gear first and set aside.

Remove intake VANOS gear without dropping the timing chain.

Install special tool as shown below. Write in the correct tool number in the spaces provided.

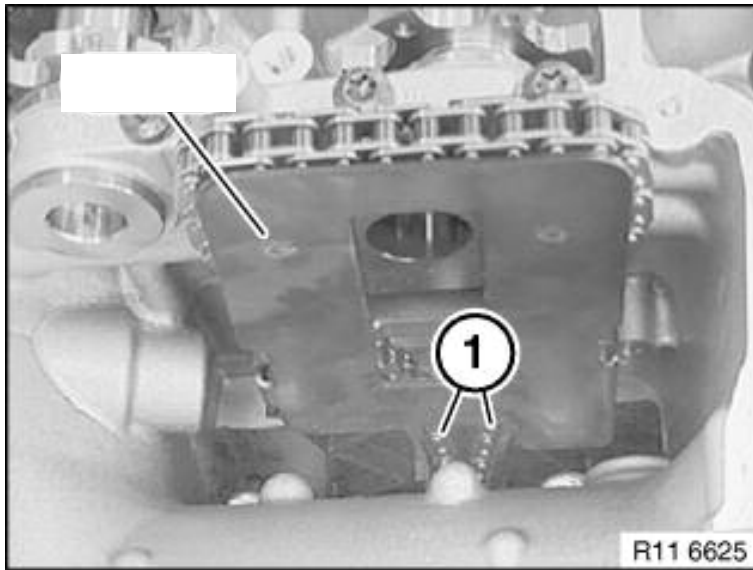

Proceed with removal of the intake and exhaust camshaft using special tools.

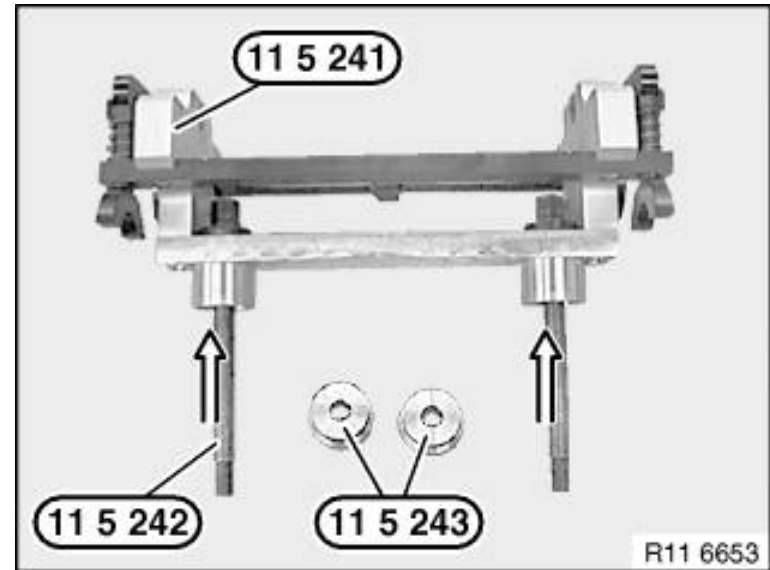

CAUTION!!!

When removing the intake camshaft, there are special tool inserts (115243) which should be installed into the camshaft removal tool (115241).

Note: When removing the exhaust camshaft, the inserts (115243) should be removed from the tool.



Workshop Exercise - Engine Disassembly

Once the intake and exhaust camshafts are removed, remove the tappets (HVA) and proceed with head bolt removal. Loosen bolts in proper sequence (from 12 to 1). Retrieve all cylinder head bolt washers when removing head bolts.

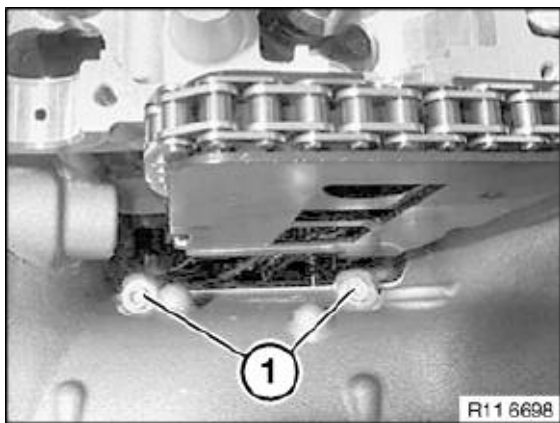

Remove cylinder head and inspect piston installation for reference. Note coolant and oil passages.

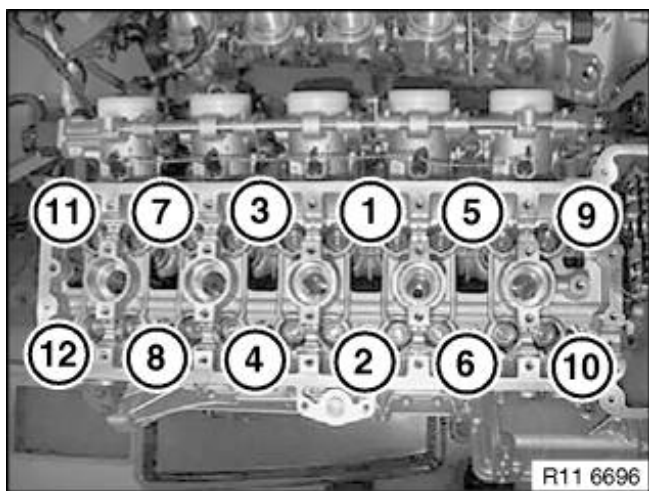

What is the minimum thickness of the cylinder head?

Is it possible to machine the cylinder head sealing surface?

Re-install the cylinder head and tighten the head bolts in proper sequence (1-12).

Since this is a trainer engine, do not tighten head bolts to full torque.

Fill in the chart below with the proper head bolt torque specifications.

Torque Specification (M10 X1.5X110 bolt)	Measurement
Joining Torque >	
Torque Angle >	
Torque Angle >	
Torque Specification (M6 bolt on front of cyl head)	Measurement
Torque	



Workshop Exercise - Engine Assembly

Re-install tappets (HVA) noting the location of the “anti-torsion” pin. Proceed with installation of the intake and exhaust camshafts, starting with the exhaust camshaft.

Be sure to install camshafts with the numbers facing upwards and aligned to cam timing tools. Install camshaft bearing caps in proper order as shown below.

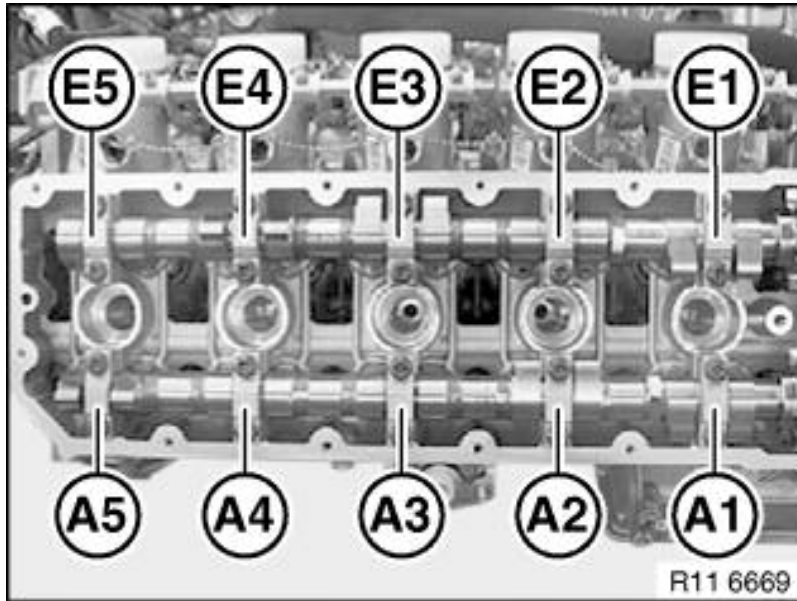

Depress camshafts with special tool and secure bearing caps. Do not tighten the camshaft bearing caps to full specification on the trainer engine.

Once the camshaft installation is complete, proceed with the installation of the intake and exhaust VANOS gears. Install intake VANOS gear first.

Ensure that the timing chain does not bind during installation.

Install special tools as shown below. Be sure that the camshaft locking tools are still in place before tightening the camshaft central bolts.

Tighten camshaft central bolts to the proper specification and remove special tools.

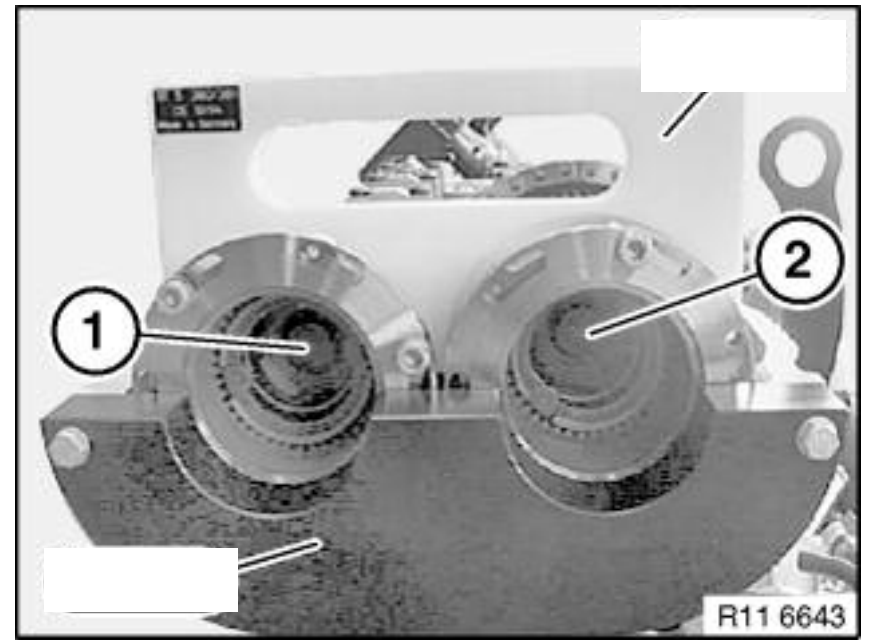

Write in the correct tool number in the spaces provided.



Workshop Exercise - Engine Assembly

Note: Before proceeding, remove M8 X 18mm lock bolt (2) as shown below.

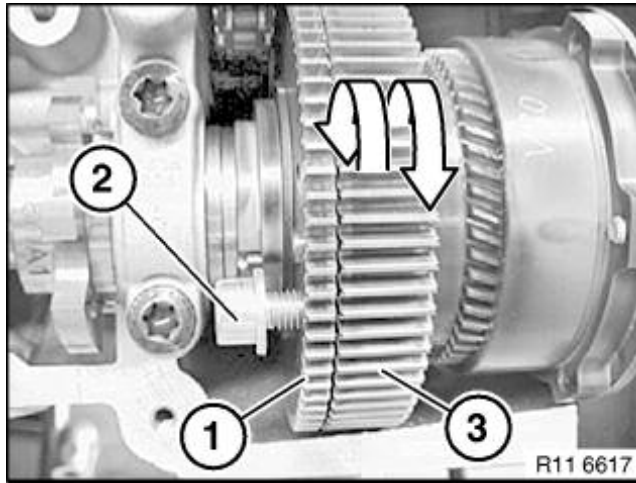

Re-install bolt for timing chain guide rail and install timing chain tensioner (1).

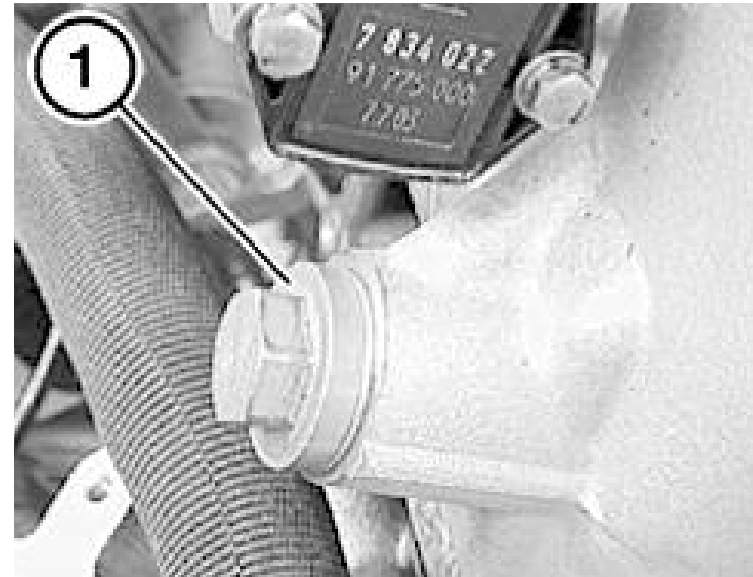
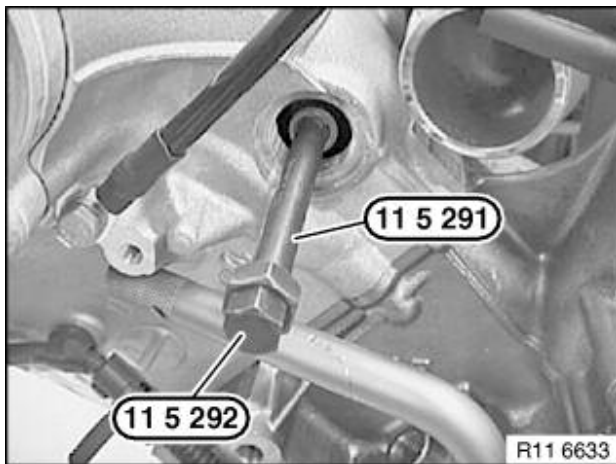

Proceed with installation of the VANOS units.



Workshop Exercise - Engine Assembly

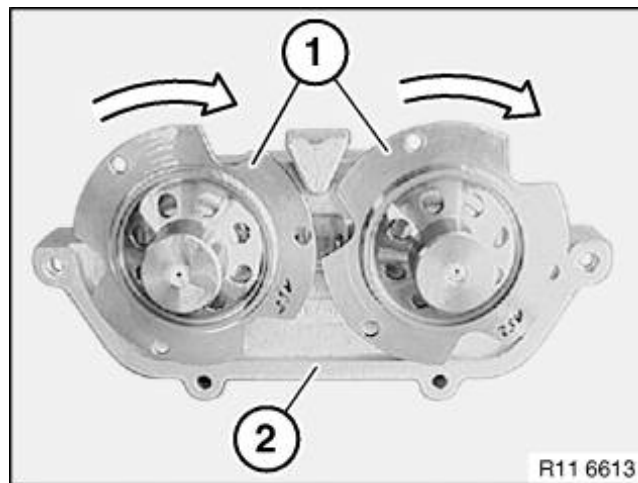
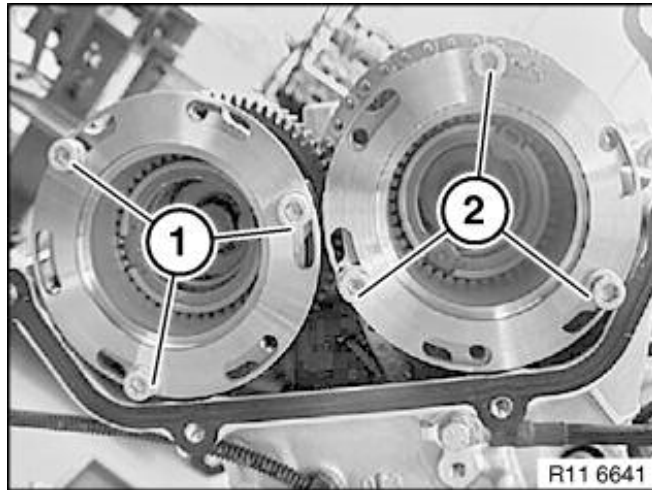

Loosen bolts (see top picture 1 and 2) 90 degrees. Before installing VANOS adjusting unit, ensure that the thrust plates (see lower picture - 1) are fully retracted and rotate freely without binding.

Note: There should be a gap of approximately 8mm at this point during installation.

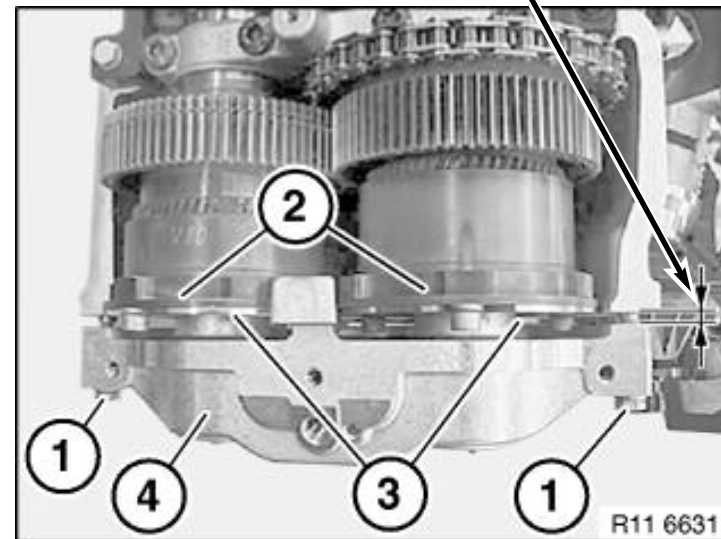

Install VANOS adjusting unit (with gasket). Position the adjustment unit using the outer bolts (1), but **do not tighten** bolts. Ensure that the VANOS gears (2) are fully extended. Align thrust plates (3) and make sure that the thrust plates are flush with the VANOS gears. Install the (exposed) hex (Allen) bolts, tighten and then loosen 90 degrees.

Before tightening the bolts (1) for the VANOS unit, ensure that all of the hex (allen) bolts (with and without washers) are loose. Tighten bolts (1) in increments of 1/2 turn.

While tightening bolts (1) observe that the outer sleeves will rotate and retract 8mm.



Workshop Exercise - Engine Assembly

Once the VANOS adjusting unit has been seated and all bolts tightened. Proceed with the final installation and tightening of the hex (allen) bolts.

Note: Do not rotate engine unless the hex (allen) bolts are tight. Before rotating the engine, tighten the exposed bolts. Failure to do so will alter camshaft timing.

Tighten all bolts (with and without washers) to 10Nm. Rotate the engine through 120 degree increments to access all bolts.

Continue with installation of the Bank II (6-10) VANOS unit by following the same steps.

At this point, CHECK the camshaft timing. If not correct, proceed with necessary steps to ADJUST camshaft timing.

Re-install cylinder head covers, ignition coils and the ionic current control units.

What is the correct torque specification for the cylinder head cover bolts?

What should be noted regarding the installation of the ionic current control units?





Workshop Exercise - Engine Disassembly

Invert engine for access to bedplate. Proceed with removal of bedplate assembly.

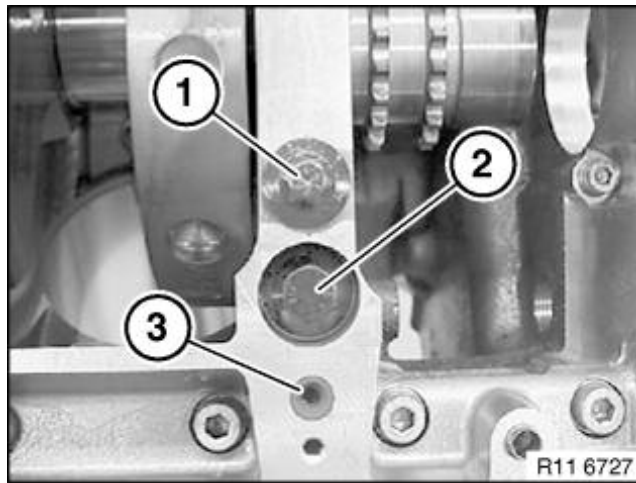

First remove all M8 fit bolts (#2 - above left) completely from engine. Next, remove the M11 main cap bolts (#1- below left). Then proceed by removing the remainder of the hex (allen) bolts.

Then remove the bedplate, paying close attention to the main bearing installation position. Take this opportunity to review engine construction, look over oil passages and bedplate sealing grooves etc.

Proceed with re-installation of bedplate.

Note: Bedplate does not use locating dowels, the M8 “fit” bolts provide the locating reference for the bedplate. Therefore proper installation is critical to prevent engine damage.

Install bedplate as shown on right. Install two M8 fit bolts diagonally as shown on right.

Tighten only the two M8 bolts to 8 Nm.

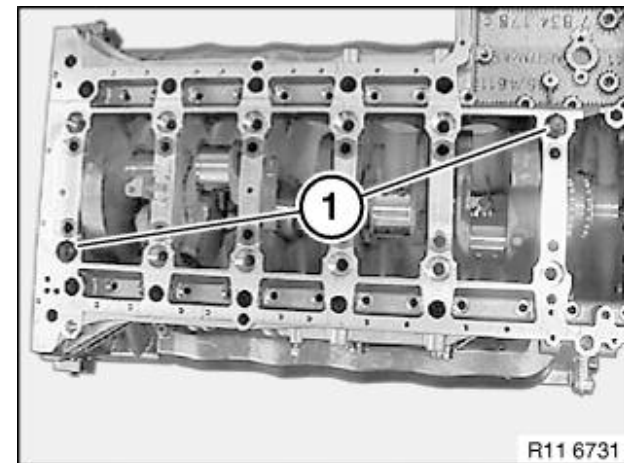
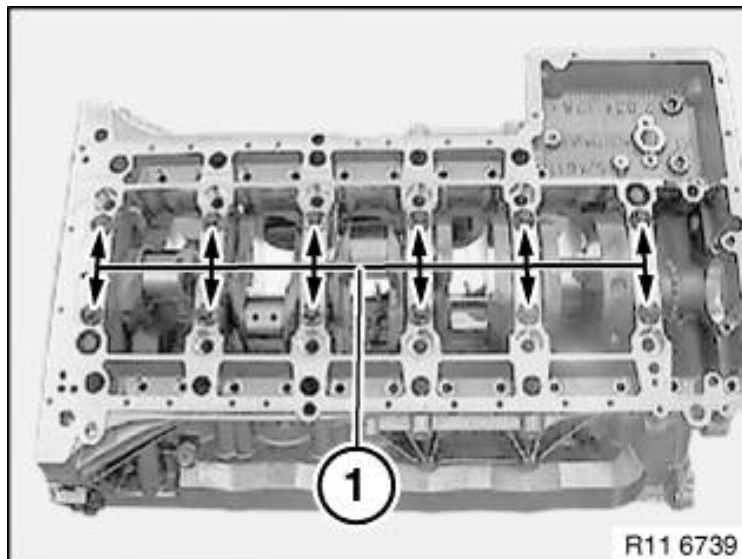



Workshop Exercise - Engine Assembly

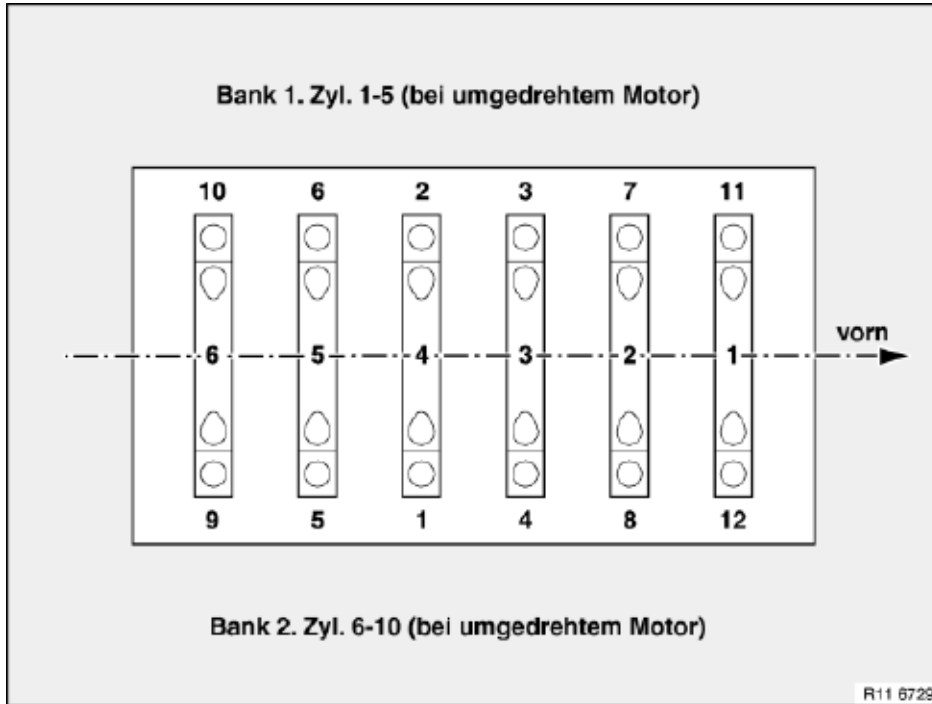

Install the M8 “fit” bolts and tighten in sequence (For trainer engine only tighten to 15Nm)

Install remaining bolts, tighten in sequence. (minimum torque).

Proceed and install all, M11 main bearing cap bolts. And tighten in sequence (on the trainer engine only tighten to 30Nm).

What is the difference in the tightening procedure between “old” main cap bolts and “new” main cap bolts?



Workshop Exercise - Engine Assembly

After bedplate installation is complete, proceed with the installation of the engine oil pump and VANOS high pressure pump.

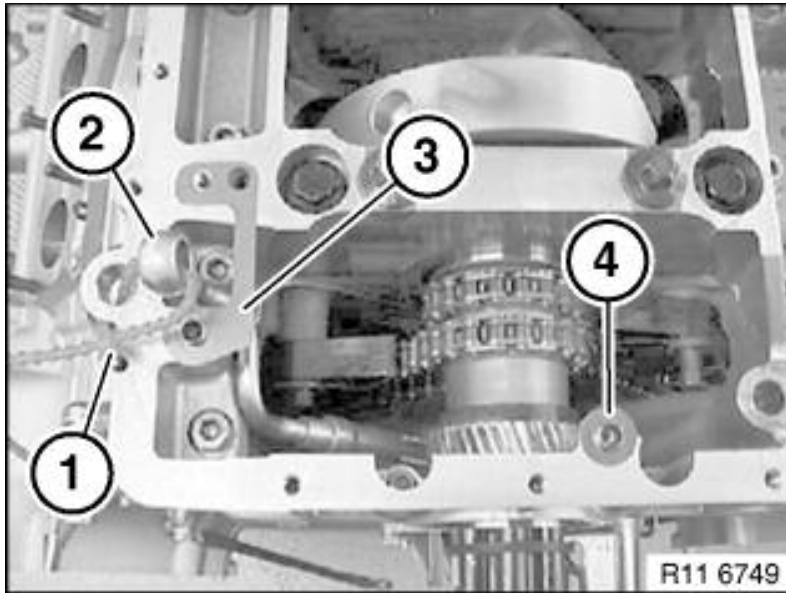

Re-install VANOS pump, note installation position of the shims (3 and 4 above).

What special tool is used to check the “backlash” of the VANOS pump gear? And, what is the backlash specification?

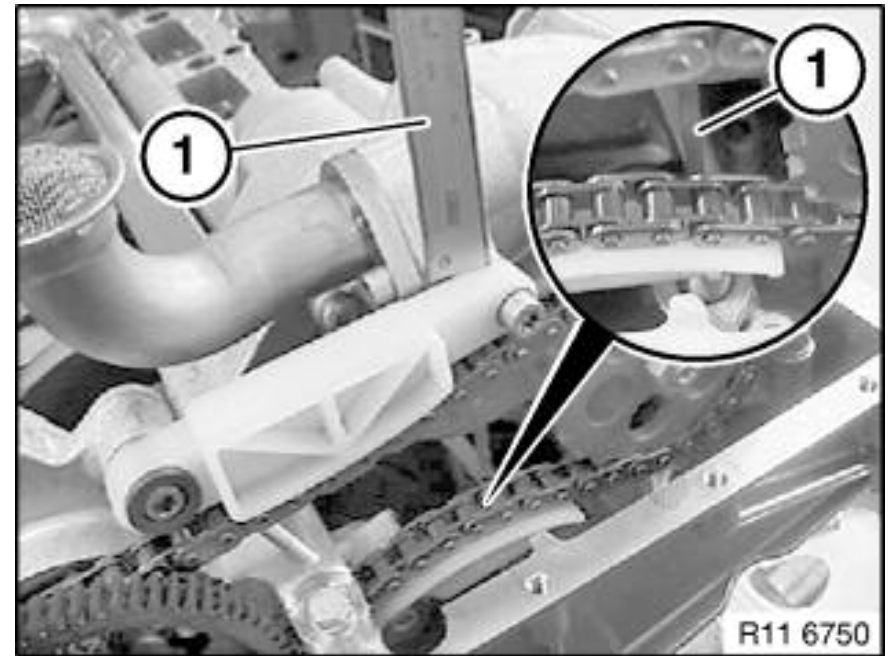

Re-install engine oil pump as per repair instructions. Measure travel of chain tensioner piston as shown.

What is the specification for the travel of the chain tensioner?



Workshop Exercise - Engine Assembly

If the chain tensioner travel is out of specification, how is it adjusted?

Re-install oil pan and observe proper bolt installation. Record bolt descriptions and bolt torque in the chart provided.

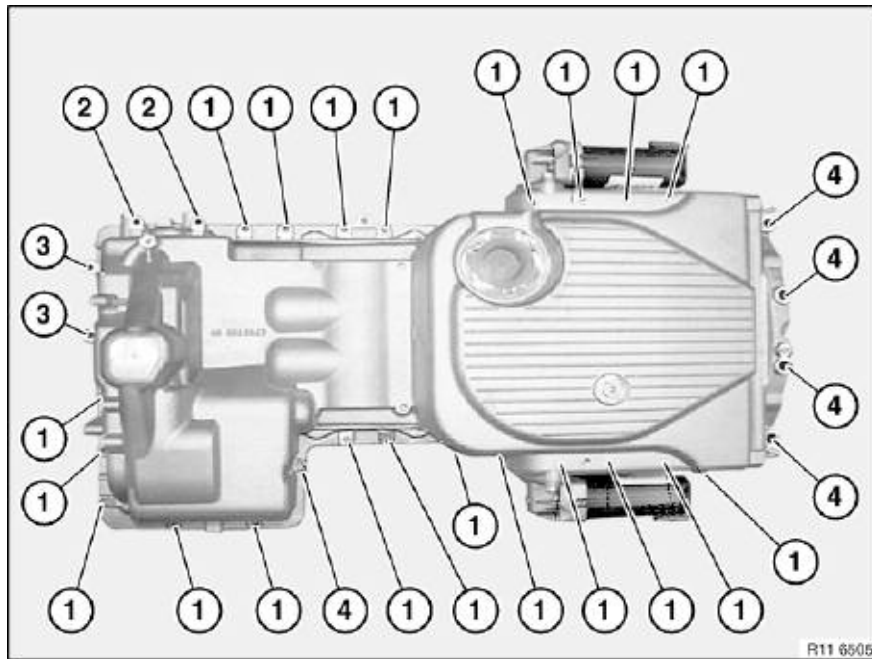

Bolt #	Bolt Description (type and amount)	Torque Specification
1	M6 X 22 Hex Bolt (10mm) 23 bolts total	
2	M6 X 40 Hex Bolt (10mm) 2 bolts total	
3	M6 X 75 Hex screw T30 Torx 2 bolt total	
4	M6 X 22 Hex Screw T30 Torx 5 bolts total	

Re-attach VANOS high pressure hoses.

Re-install trim covers and intake plenum.

Check over engine and re-install any additional items such as harmonic balancer etc.



Classroom Exercise - Review Questions

1. Is it possible to remove the cylinder head without removing the camshafts? (Why or Why not?)

2. What is the difference between TDC and the “39 degree” position?

3. What is the purpose of the “split gear” on the exhaust VANOS gear?

4. When removing the exhaust camshaft, what should be done to the special tool 115 241 and why?

5. What bolts should be replaced when performing the R&R of the VANOS gears?

6. What is the purpose of the M8 “fit” bolts on the bedplate assembly?

NOTES

PAGE

S65B40 Engine

Engine Block with Bedplate Construction

The construction and materials used on the E65 engine of the E9X M3 are identical to the S85 engine on the M5/M6.

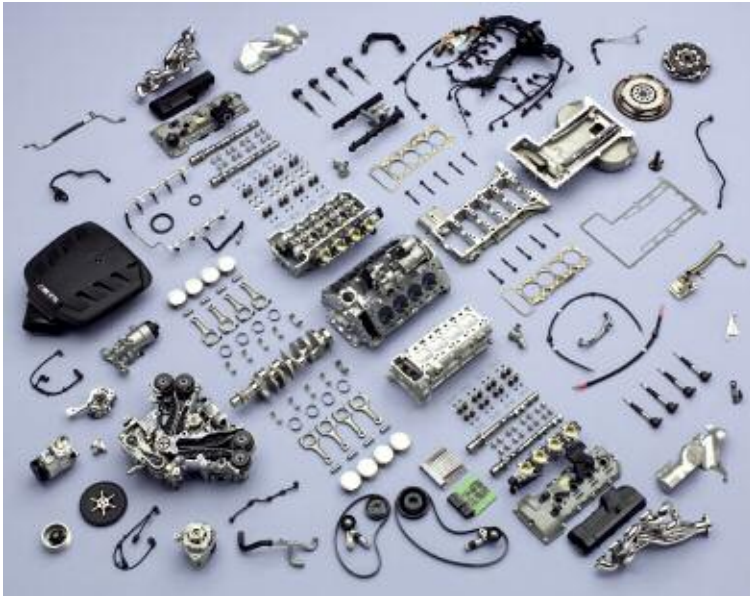

The upper low-pressure die-cast crankcase is made from an aluminum-silicon alloy.

The cylinder bores are formed using exposed hard silicon crystals, rendering the use of cylinder liners unnecessary.

The lower crankcase (bedplate) is also constructed using die-cast aluminum. Due to the extreme forces, grey cast iron inlays are used to reinforce the bedplate construction.

These also limit crankshaft bearing clearances over a greater temperature range and thus have a positive effect on the oil flow rate.

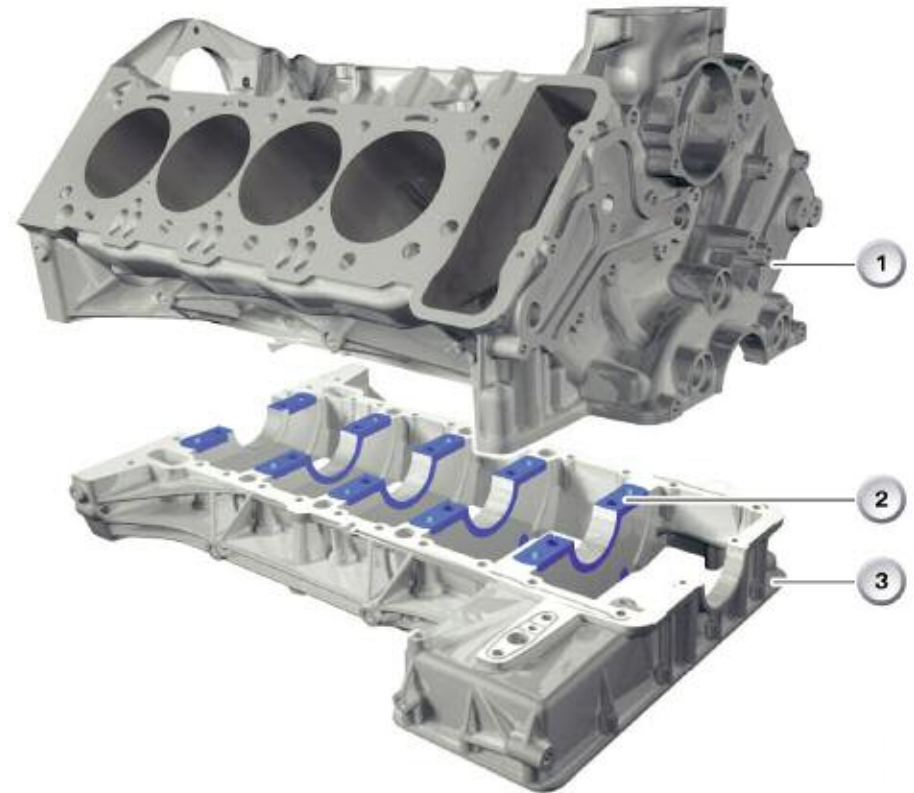

S65B40 Engine block with bedplate construction

Index	Explanation
1	Engine block (upper section)
2	Grey cast iron inlays
3	Bedplate construction (lower section)

Crankshaft

The five-bearing crankshaft is forged from a single piece, including the two double-chain gears for driving the valve train. The gear wheel for the oil pump drive is flange mounted.

The E65 crankshaft possesses high torsional strength at a relatively low weight.

The crank pin offset is 90° and the cylinder spacing is 98mm.

The crankshaft end play is controlled by a thrust bearing located at the fifth main bearing.

The diameter of the main bearing journal is 60 mm.

For design reasons, the firing order 1-5-4-8-7-2-6-3 was chosen for the S65, instead of the 1-5-4-8-6-3-7-2 firing order more commonly employed in BMW V8 engines.

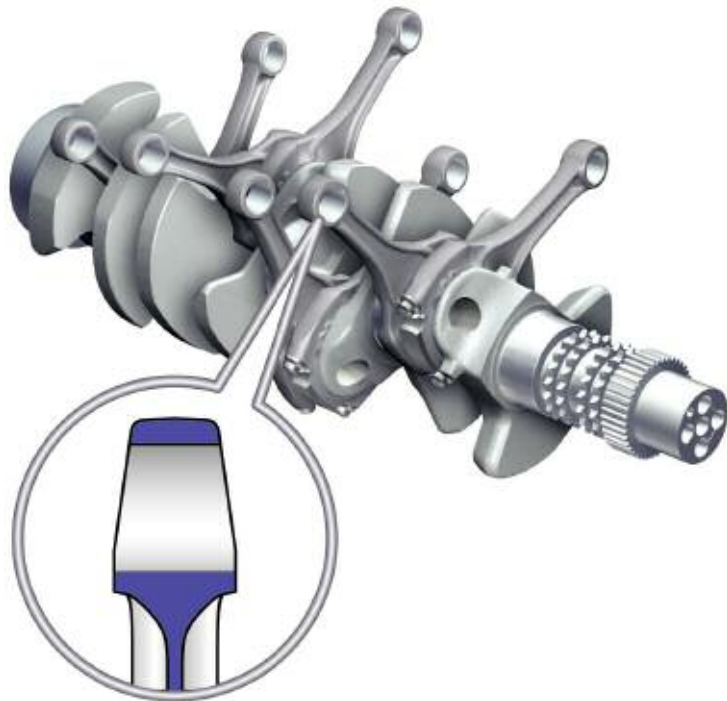

Connecting Rods

The high tensile steel connecting rods are cold cracked.

The upper (small end) section of the connecting rod has a trapezoidal shaped design for weight reduction while the large end of the connecting rod is asymmetrically ground to reduce the total length of the engine. This means that the installation of the connecting rods is direction-specific.

Note: The identification marking of the bearing shells is engraved on the crankcase and on the first crank web. For further information, see the service documentation available on TIS or ISTA.

Pistons

The piston design is the same as the S85 piston.

Pistons are manufactured from a cast aluminum alloy and weigh approximately 480 grams including wrist pin and piston rings.

As on the S85 the pistons have a galvanized iron coating [Ferrostan] and a running-in layer containing tin.

The installation position of the pistons is direction-specific.

Index	Explanation
1	Pistons
2	Taper-faced ring
3	Wrist pin
4	Piston skirt
5	Oil scraper ring (VI system)
6	Compression ring (plain compression ring with spherical contact face)

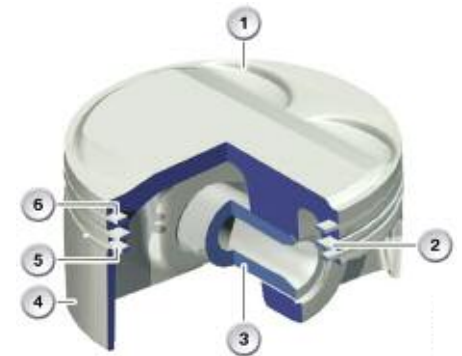

Oil Supply

Two oil pumps are installed in the S65 engine; the oil return pump, which is driven via a gearwheel by the crankshaft, and the volume flow-controlled main oil pump, driven via chain drive by the oil return pump.

In the S85, the VANOS high pressure pump is installed instead of the S65 oil return pump, and the S85 oil return pump is contained in a housing together with the main oil pump (tandem pump).

Since there is no space to install a tandem pump in the S65, the oil return pump has been moved from the main oil pump housing and installed instead of the VANOS high-pressure pump. This allows the pump drive principle (crankshaft => gearwheel => pump => chain => pump) to be maintained. As in the S85, the volume flow-controlled main oil pump is a hinged-valve oil pump with a feed capacity adjusted to suit the VANOS low-pressure system.

The duocentric design of the oil return pump ensures that oil is always available at the inlet pipe of the main oil pump in the rear area of the oil pan, even when braking sharply from high speeds.

The electrical oil return pumps installed in the S85 for scavenging the cylinder heads are no longer required, which results in a further weight saving. This is made possible by the lower number of cylinders, modification of the oil return routes, and the large capacity of the oil pan.

The oil pan has a capacity of 8.3 liters (S85 9.3 liters).

The oil supply is also guaranteed at extreme longitudinal and lateral accelerations of up to 1.4 times the normal gravitational acceleration.

The oil filter housing is installed on the engine.

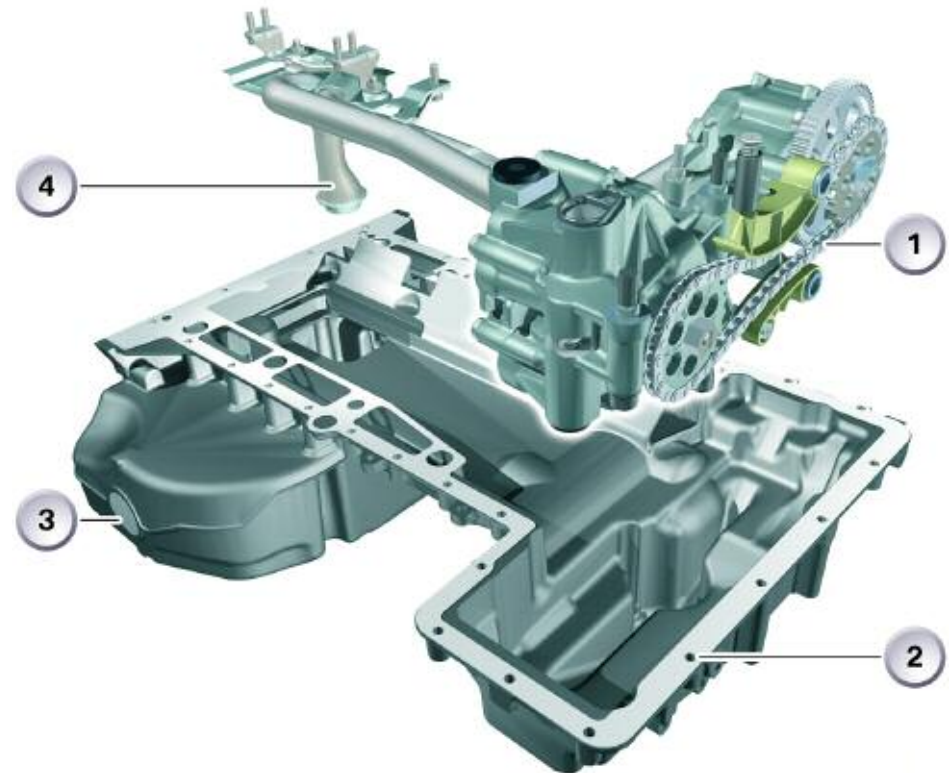

Index	Explanation
1	Oil pump chain
2	Front, smaller section of the oil pan
3	Main oil pan
4	Oil intake of the main oil pump

Oil Supply Hydraulic Circuit Diagram

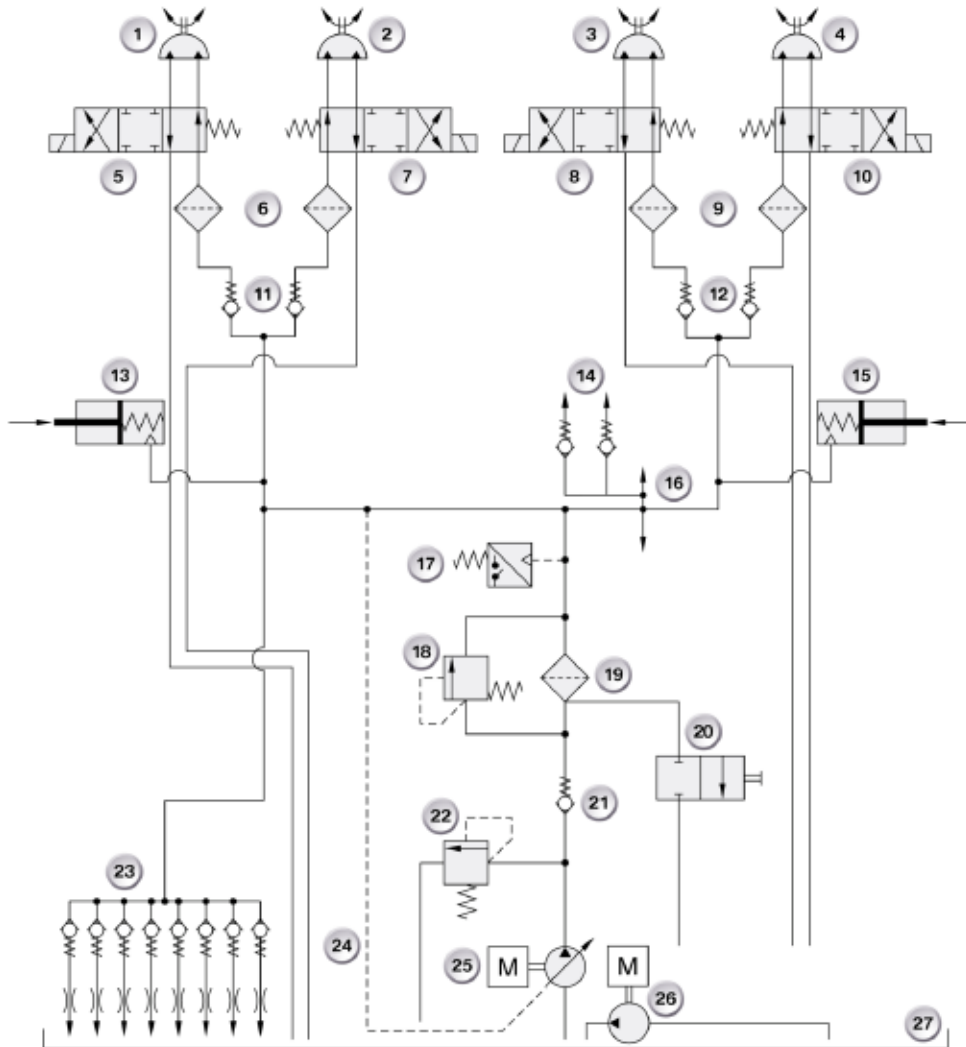

Index	Explanation
1	Cylinder bank 1 VANOS exhaust hydraulic motor
2	Cylinder bank 1 VANOS inlet hydraulic motor
3	Cylinder bank 2 VANOS inlet hydraulic motor
4	Cylinder bank 2 VANOS exhaust hydraulic motor
5	Cylinder bank 1 VANOS exhaust multi-way adjustment valve
6	Cylinder bank 1 VANOS sieve filter (max. 300 μm) before multi-way adjustment valve
7	Cylinder bank 1 VANOS inlet multi-way adjustment valve
8	Cylinder bank 2 VANOS inlet multi-way adjustment valve
9	Cylinder bank 2 VANOS sieve filter (max. 300 μm) before multi-way adjustment valve
10	Cylinder bank 2 VANOS exhaust multi-way adjustment valve
11	Cylinder bank 1 VANOS non-return valve
12	Cylinder bank 2 VANOS non-return valve
13	Cylinder bank 1 chain tensioner
14	Cylinder bank 1 and 2 non-return valve from chain lubrication
15	Cylinder bank 2 chain tensioner
16	Main oil channel (lubrication points engine block and cylinder head)
17	Oil pressure switch
18	Oil filter bypass valve
19	Oil filter
20	Oil filter outlet aperture
21	Non-return valve
22	Pressure limiting valve
23	Piston cooling nozzles
24	Oil pressure regulation line
25	Volume flow-controlled hinged valve main oil pump
26	Oil return pump
27	Sump

Cylinder Head

The cylinder head is constructed from a single piece of aluminum alloy. To reduce the number of sealing faces, the secondary air channel has been integrated back into the cylinder head.

The design of the cylinder head is based on the S85 engine. Compared to the S85, changes have been made in the front of the engine, the VANOS system and the timing chain.

Compared to the S85, the intake and exhaust tracts airflow has been optimized. The integrated idle air channel has been discontinued and replaced by an idle air bar for each cylinder bank.

As in the S85, the camshafts are manufactured as a hollow-cast, one-piece construction with integrated sensor gears.

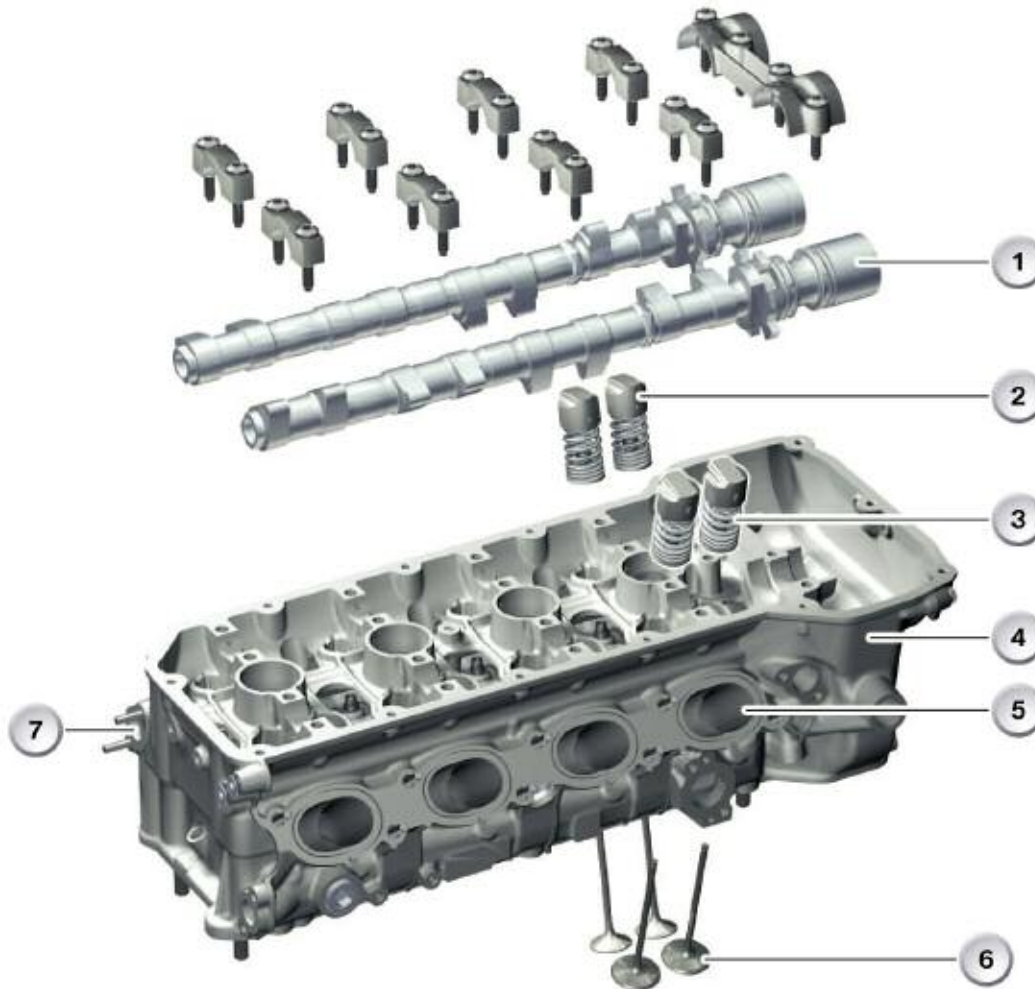

Index	Explanation
1	Camshaft
2	Bucket tappet with hydraulic valve clearance adjustment
3	Beehive-shaped valve springs
4	Cylinder head
5	Intake passage
6	Valve
7	Connection flange of the integrated secondary air channel

Hydraulic Bucket Tappet

As on the S85, the S65 uses weight-optimized valves with a 5mm stem diameter and bucket tappets with hydraulic valve clearance adjustment.

The convex camshaft contact surface and the integrated rotational lock of the hydraulic tappets provide excellent camshaft following with limited valve rotation. This results in effective valve lift characteristics with the smallest possible tappet diameter and a reduction in valve train total mass. (ideal for high engine speeds).

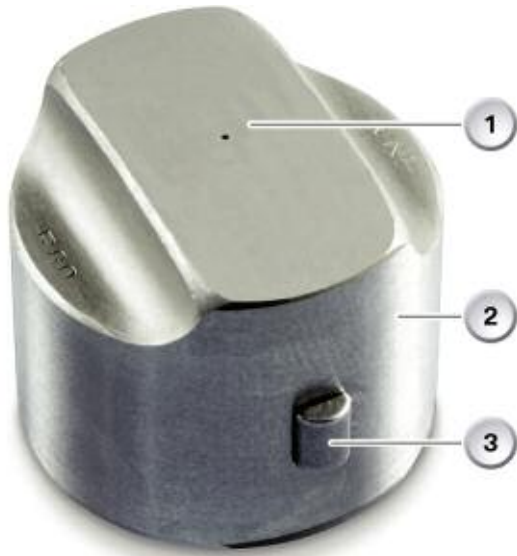

Index	Explanation
1	Convex contact surface
2	Bucket tappet
3	Guide lug rotational lock

Camshaft Drive

As in the S85, the intake camshafts are driven by chain drive and the exhaust camshafts are driven by a gearwheel drive. This means that the intake and exhaust camshafts always have an opposite direction of rotation. In contrast to the S85, which works with two single-roller chains between the crankshaft and the intake camshafts, in the S65, two double-roller chains are used. This is because of the higher chain drive load in the V8.

The VANOS adjustment units are an integral component of the valve control and are mounted on the relevant camshaft by a central bolt.

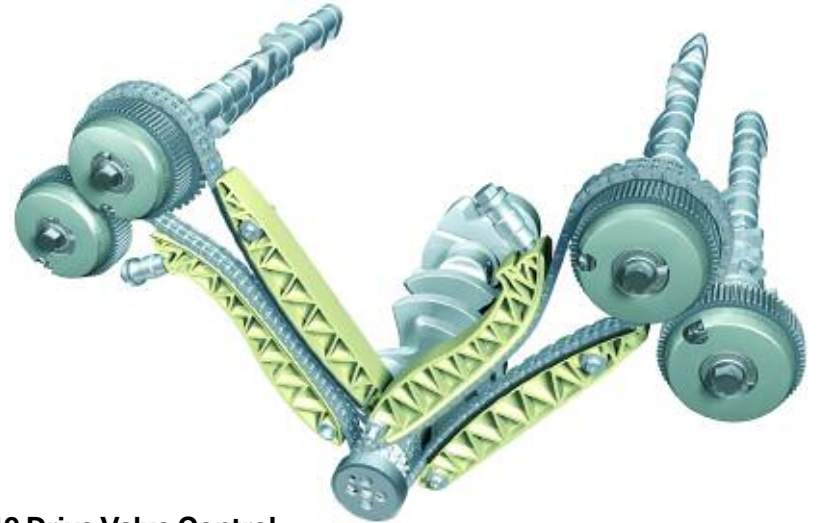

S65B40 Drive Valve Control

Technical Data	E92 M3	E46 M3	E6x M5/M6
Engine identifier	S65B40	S54B32	S85B50
Camshaft drive	2x double-roller chain	Double-roller chain	2x single-roller chain

Note: The central bolts of the intake and exhaust side have a CCW thread, please refer to the repair instructions.

VANOS

The compact double VANOS system fitted to the S65 engine operates at normal oil pressure, unlike the S85 engine (which uses high oil pressure).

The low-pressure system means that the high-pressure pump, additional pressure lines and reservoir are unnecessary. This results in a space saving as well as a weight reduction of approximately 8.4 kg/18.5 lb. The use of low pressure VANOS is made possible by the considerably stronger torque variations at the

S65B40 VANOS hydraulic motor

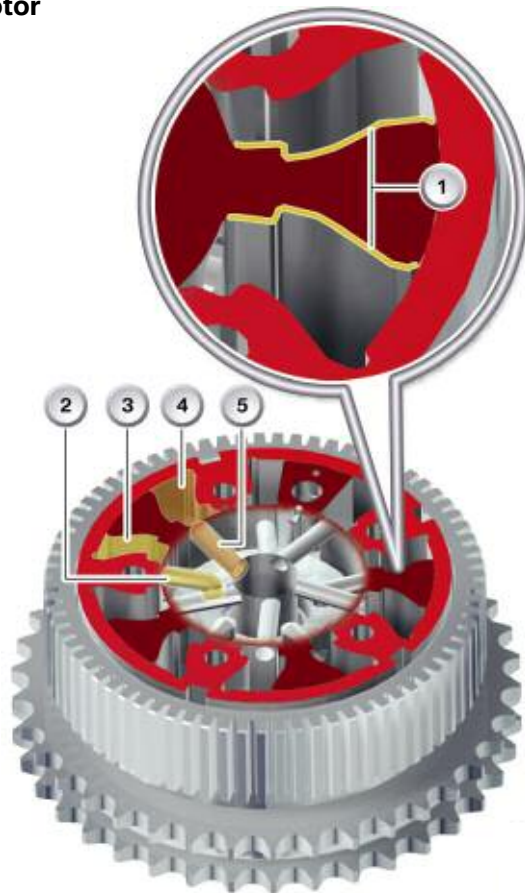

camshaft compared to the 10 and 6-cylinder engines, particularly in the lower engine speed range. The low-pressure system uses these torque variations to adjust the overall VANOS gear ratio.

The oil is directed to the sealed oil chambers 3 and 4 (see below) of the VANOS adjustment unit.

When the chambers are pressurized with oil pressure, one chamber allows the camshaft to advance while the other chamber allows the camshaft to retard.

Index	Explanation
1	Optimized hydraulic rotor pressure surfaces
2	Optimized inlet channel oil chamber 1
3	Oil chamber 1
4	Oil chamber 2
5	Optimized inlet channel oil chamber 2

The VANOS oil pressure is supplied by the engine's main oil pump. The VANOS oil flow is controlled by one multi-way valve for each camshaft. These VANOS multi-way valves are controlled by the MSS60 and are directly installed in the cylinder head.

As in the S85, the VANOS adjustment unit of the intake camshaft drives the VANOS adjustment unit of the exhaust camshaft by means of a constantly meshed gear.

S65B40 VANOS Hydraulic schematic (single cylinder bank)

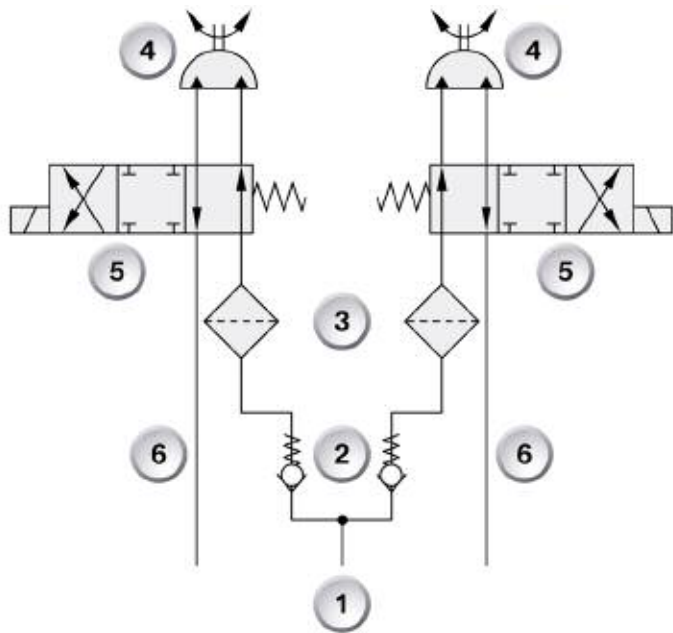

Index	Explanation
1	Oil supply from the main oil gallery
2	Non-return valves
3	Sieve filter upstream from control valves
4	Hydraulic motor at the intake and exhaust camshaft
5	Multi-way adjustment valves intake and exhaust side
6	Oil return flange to the oil sump

At zero pressure, a locking pin (2) (see below) holds the VANOS unit in the “normal” or engine start position.

The spiral-wound spring (3) is also used for coordinating the adjustment time between the advance and retard adjustment. In contrast to other BMW engines, the spiral wound spring for the intake and exhaust sides is mounted in the opposite working direction, since the camshafts in the S65 rotate in the opposite direction.

The design principle of the M VANOS hydraulic motor is based on the VANOS system in current BMW engines and is optimized for the S65 in terms of oil supply, drainage diameters and in rotor surface area.



Index	Explanation
1	Locking pin spring
2	Locking pin
3	Spiral-wound spring

The setting angle of the intake camshaft is 58° in relation to crankshaft rotation. The exhaust camshaft has a setting angle of 48° in relation to crankshaft rotation. As in the S85 engine, this VANOS also reaches an adjustment rate of 360° camshaft per second.

Note: The VANOS adjustment unit must NEVER be disassembled, once apart they must be replaced. Always follow the proper service and repair instructions.

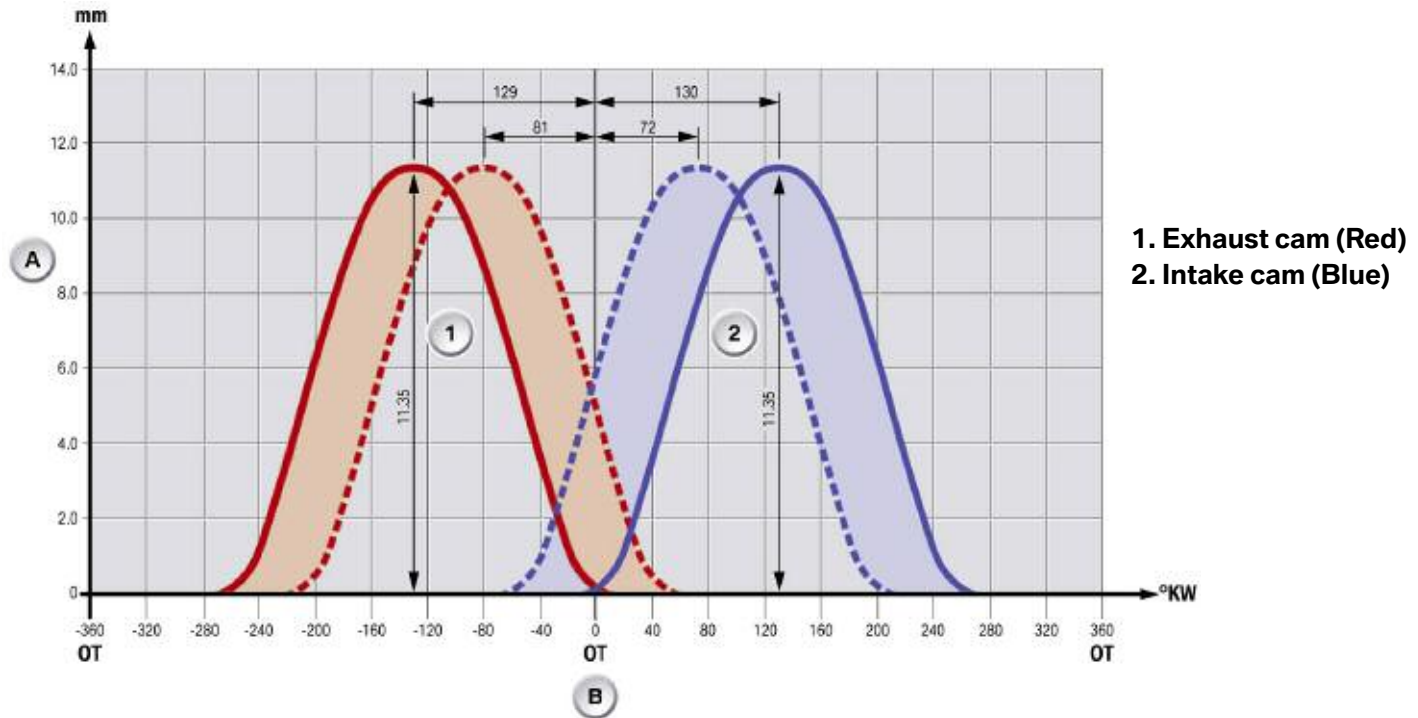

1. Exhaust cam (Red)
2. Intake cam (Blue)

Technical Data	E92 M3	E46 M3	E6x M5/M6
Engine identifier	S65B40	S54B32	S85B50
Variable camshaft control VANOS	2x double (engine oil pressure) oscillating rotor VANOS	Double high-pressure VANOS	2x double high-pressure VANOS
Adjustment range E/A [°KW]	72-130/81-129	70-130/83-128	79-145/91-128
Camshaft Setting Angle E/A [°KW]	58/48	60/45	66/37
Response time E/A [°KW]	256/256	260/260	268/260

Note: [°KW] is Kurbel Welle or Crankshaft Degrees

Individual Throttle Body System

The design principle of the S65 individual throttle valve air intake system is the same as the S85 and consists of eight individual throttle valve assemblies and two electrical throttle valve actuators. One electric throttle valve positioner activates four individual throttle butterflies of one cylinder bank, which are mechanically coupled. The throttle valve position for each cylinder bank is recorded using a double throttle valve sensor on the shared throttle body shaft.

A signal is sent directly to the throttle valve actuator responsible for this cylinder bank. The throttle valve actuator can therefore independently adjust the throttle valve position specified by the MSS60.

The second signal is sent to the MSS60 for checking purposes.

For communication with the MSS60, the two electrical throttle valve actuators use a shared DK-CAN bus (DK-CAN).



Index	Explanation
1	Double throttle valve sensor cylinder bank 1 and 2
2	Individual throttle valve assemblies
3	Electrical throttle-valve actuator

Air Intake System

The combustion air enters the engine via three flow-optimized air guides. An air inlet is located on the left side of the hood (driver side). To maintain an optical balance in the appearance of the engine hood, another intake grill is located on the right side, but this is blind and does not perform any function.

The second air inlet is located behind the kidney grills of the BMW kidney.

The third air inlet is located on the lower left corner of the front bumper.

The S65 has a large, single-piece intake air collector that combines both cylinder banks.

A cylindrical air filter element (4) with an enlarged surface area is used.

The filtered air flows into the intake manifold, through eight integrated individual inlet pipes and into the individual throttle valve assemblies.

To optimize air resistance, no air-mass sensor is installed in the intake area.

The air flow is determined using a model based calculation from the opening of the throttle valve assemblies and the idle speed actuator; The VANOS adjustment position, engine speed, air temperature and the atmospheric pressure are also factors.

For safety reasons, an additional pressure sensor is mounted in the idle speed system (see idle speed control).

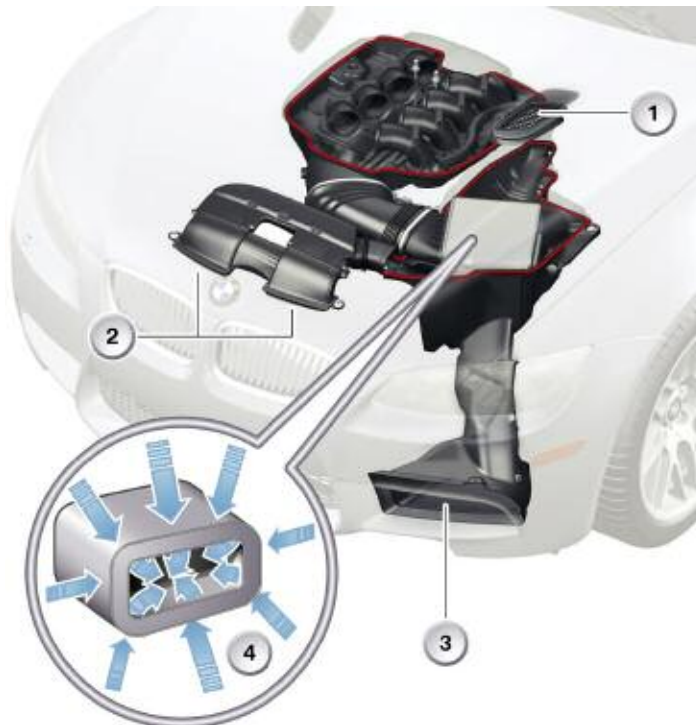

Index	Explanation
1	Engine hood air inlet
2	Air inlet behind the ornamental grills of the BMW kidney
3	Air inlet in the bumper
4	Air filter element

Idle Control System

One common idle speed actuator for both cylinder banks controls the air supply at idle speed and at low engine loads. The idle speed actuator is located in the V formed by the two cylinder banks, and controls the idle air supply using a throttle valve. The air enters the shared bar for each cylinder bank via the relevant air ducts, and from there is guided into each throttle body below the throttle valve.

The idle speed actuator receives control instructions from the MSS60 via its own local CAN bus (LoCAN).

To ensure emergency operation in the event of the failure of one or both throttle valve sensors (even without the hot film air-mass sensor), an additional pressure sensor is integrated on the idle air bar (as in the S54B32HP (M3 CSL)). This allows evaluation of the pressure conditions behind the throttle valves. This pressure is also used for the plausibility check of filling and load in normal operation.

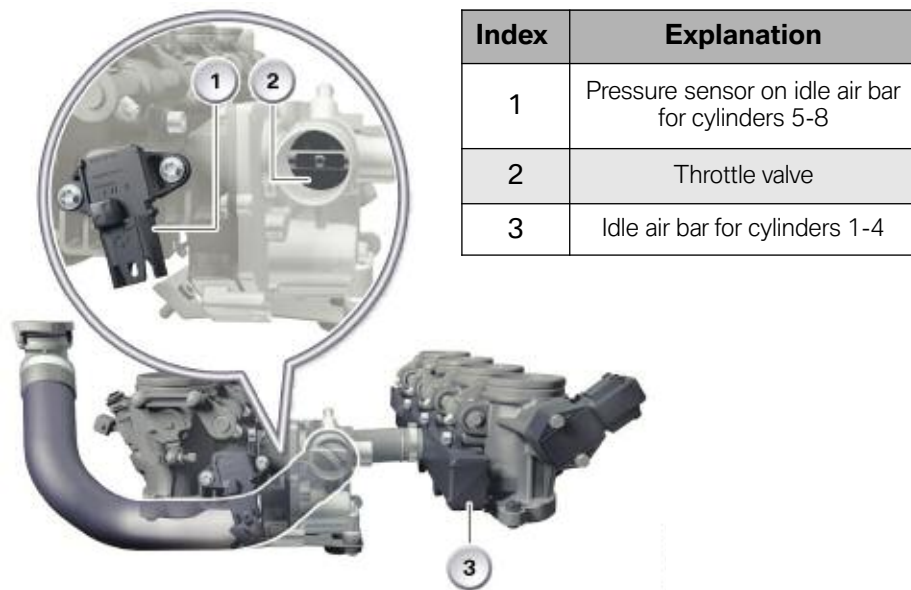

Secondary Air System

The secondary air pump is mounted on the rear of the engine in the "V" of the cylinder banks. The secondary air is guided into the relevant exhaust channel via a check valve and an air channel integrated in the cylinder head.

An upstream secondary air pump hot-film air mass sensor measures the secondary air flow. The structure and function are the same as the system in the E60 M5.

Oil Separators

The oil separators are bolted onto the cylinder head covers. The connection between the oil separator and the intake manifold is not screwed but plugged. This reduces the risk of incorrect assembly.

As is typical for the M series, no crankcase pressure control is mounted/integrated.



Cooling System

The mechanical coolant pump was taken from the S85.

The water pump belt pulley has been adapted due to the reduced water flow rate in the S65 compared with the S85. It has a larger diameter, which has allowed a reduction in pump speed.

A one-piece crossflow radiator is used to cool both banks, unlike the S85 engine which has a two-piece radiator, one part for each bank.

Oil Coolers



Index	Explanation
1	Gearbox oil cooler
2	Engine oil cooler

The following components have been adjusted for the M3:

- coolant expansion tank
- crossflow radiator
- radiator hoses
- thermostat
- electric fan

The gear oil and steering oil coolers are also installed in the series-model E9x.

The control of the electric fan is described in the MSS60 engine control system. (Please refer to the 4th Generation M3 training material available on TIS or ICP for more information.)

Complete cooler package



Index	Explanation	Index	Explanation
1	Gearbox oil cooler	3	Engine coolant cooler
2	Engine oil cooler	4	Steering oil cooler

The main belt drive drives the coolant pump and the generator, while the auxiliary belt drive drives the air conditioning compressor and the power-assisted steering pump.

The generator and the coolant pump are in the same position as in the S85. The coolant pump is identical to the S85, but has a larger belt pulley.



Fuel System

The fuel tank is based on the series production E92 tank, although the shape has been changed to accommodate the exhaust system. Both in tank units are newly designed. The fuel pump is installed in the right side unit, and the pressure regulator is installed in the left-side unit in front of the fuel filter.

The ventilation lines have been adapted, while all other lines have been taken from the E92 335i. The US release is fitted with a tank leakage diagnosis unit.

The electrical controls are described in the MSS60 engine control system. (Please refer to the 4th Generation M3 training material available on TIS or ICP for more information.)

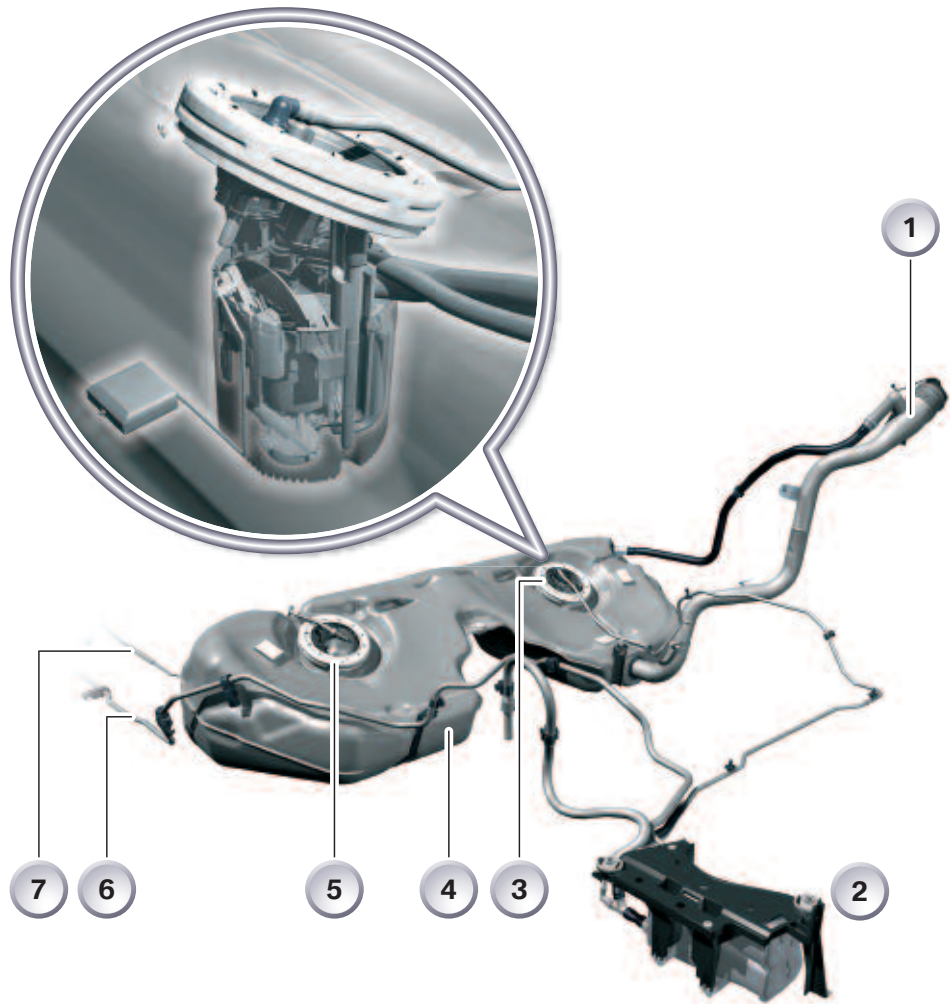

Index	Explanation
1	Tank filling supports
2	Tank leakage diagnosis unit
3	Right fuel supply unit
4	Fuel tank
5	Left fuel supply unit
6	Tank vent valve
7	Engine fuel supply line

E9X M3 Fuel tank components

Exhaust System

The exhaust pipes of the M vehicles are manufactured using the innovative internal high pressure forming technology (IHU). Using the IHU technology, the seamless stainless steel exhaust pipes are formed under a pressure of up to 800 bar. This results in extremely thin wall thicknesses of between 0.65 and 1.0 millimeters, which means both the weight of the exhaust system and the response characteristics of the catalytic converters can be optimized. At the same time, the IHU technology enables unprecedented styling and even more efficient geometric tolerances.

The largest possible pipe cross-sections are used, thus minimizing flow resistance. The complete exhaust system is manufactured in stainless steel and has a dual flow.

The 4-in-1 exhaust manifold in each cylinder bank, as used in motor sport, has a length and cross-section designed to enable optimal use of dynamics in the exhaust flow and to avoid unnecessary exhaust backpressure.

The exhaust system has one quick responding metal catalytic converter close to the engine per exhaust line, (approx. 20 cm behind the exhaust manifold), followed by the metal main catalytic converter. The front silencer and the final muffler shared by both exhaust lines with a volume of 35 liters are constructed in an absorption design.

The lambda oxygen sensors are located before and after both engine-side catalytic converters. The exhaust temperature sensor installed in previous M models is no longer required and is replaced by an internal calculation model in the control device.

The S65 fulfills the requirements of the LEV 2 classification.

Note: At maximum operating temperatures, the entire exhaust system can expand in length by 35 mm.

E9X M3 Exhaust System

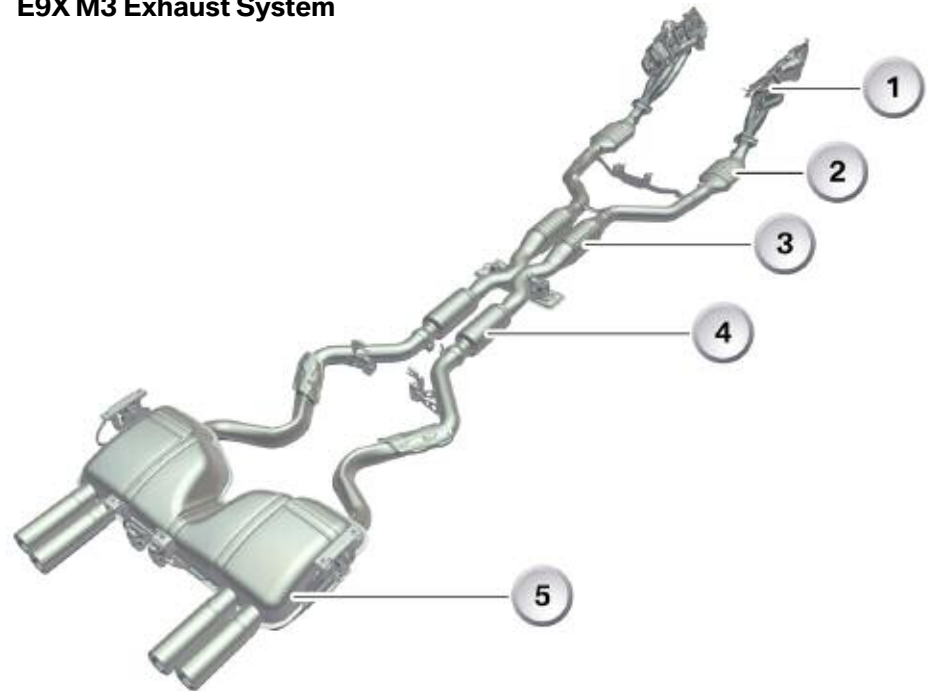

Index	Explanation
1	Manifold
2	Catalytic converter close to the engine
3	Main catalytic converter
4	Front exhaust silencer
5	Final muffler

NOTES

PAGE

S54B32 Engine

The S54B32 engine is an in-line 6 cylinder power plant. This 3246 cc displacement engine is used in the M Roadster and M Coupe.

The S54B32 is a 4-valve per cylinder dual VANOS naturally aspirated engine with high torque and high-rev concepts. High torque is developed by a large volume engine at low engine rpm and a long total gear ratio.

High-revs are achieved with a small displacement “lightweight” (internal components) engine and short total gear ratio. This powertrain provides the best of both worlds by using a 3.2 Liter in-line 6 cylinder configuration coupled to a 6 speed manual transmission.

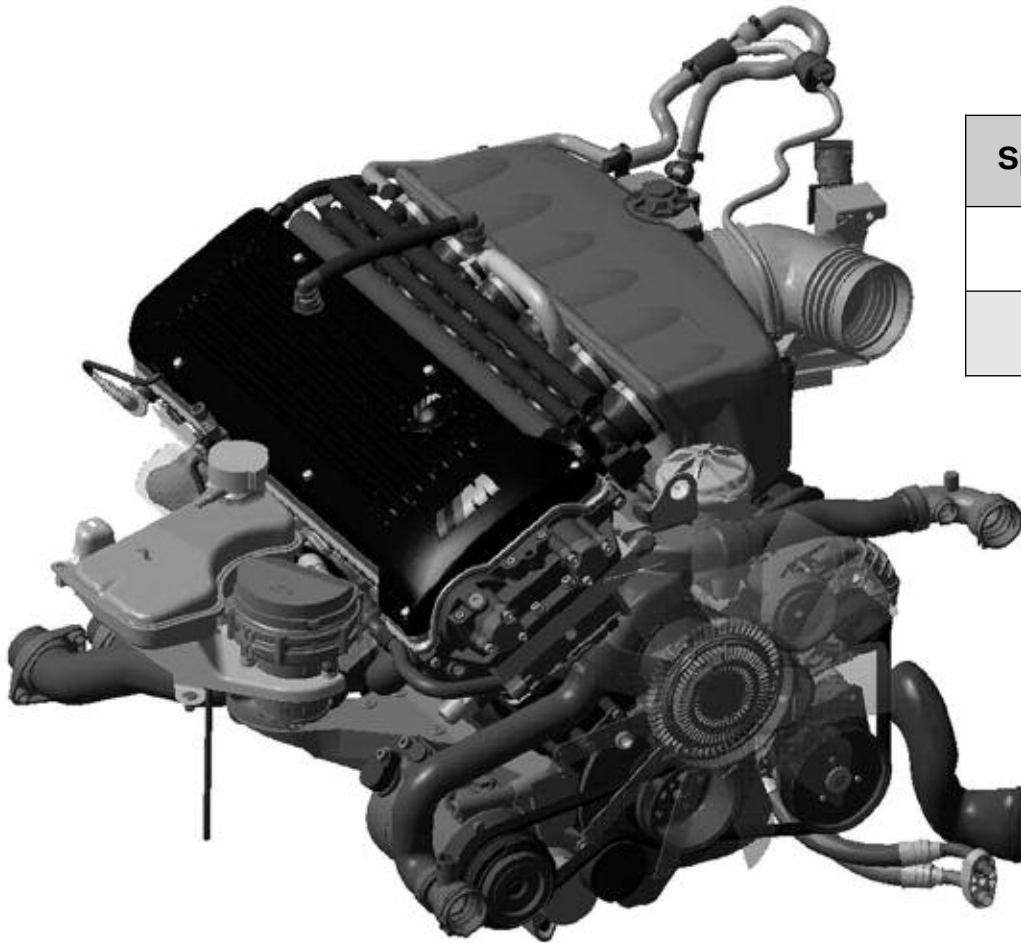

Specifications	E46 M3	M3 Roadster
Horse Power	333 hp at 7900 rpm	315 hp at 7900 rpm
Torque	355 Nm at 4900 rpm	340 Nm at 4900 rpm

Engine Block

The S54 engine block is cast iron in order to absorb the high forces produced by the crankshaft (combustion pressure and high engine rpm).

The engine block has cast provisions for 3 Knock Sensors and the Crankshaft Position/RPM Sensor (on the intake side).

The cylinder bores are 87 mm in diameter and are spaced 91 mm on center.

The “bare” block weighs approximately 105 lbs. (48 kg).

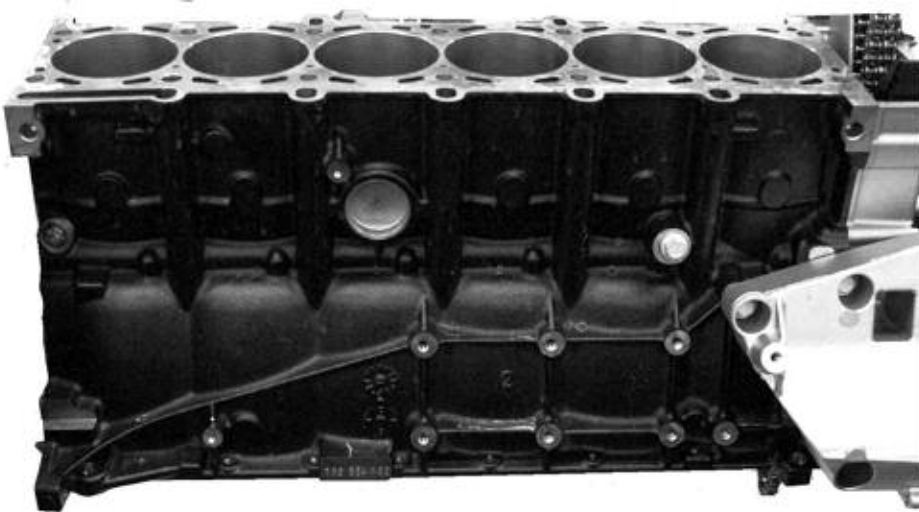

Crankshaft and Bearings

The S54 crankshaft is forged steel with 12 counterweights and a 91 mm stroke. The crankshaft is supported by 7 (60 mm diameter) main bearings with 49 mm diameter connecting rod journals.

The “thrust” bearing is a multi-piece shell assembled as a unit and is located on the number 6 main journal of the crankshaft.

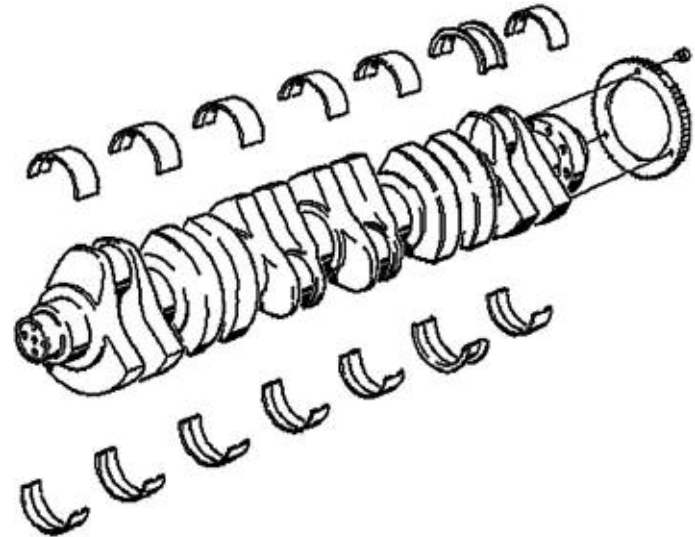

Bearing Clearance

- Main 0.02 - 0.05 mm
- Thrust (end play) 0.08 - 0.16 mm

Note: The impulse wheel is bolted to the number 6 connecting rod journal counterweight.

Connecting Rods and Bearings



The S54 uses reinforced forged steel “cracked”

The “cracked” connecting rod refers to the cap which is split off leaving rough surfaces on both the cap and the rod.

Centering of the cap on the rod is carried out through the structure of the split which eliminates the alignment sleeves. Pairing codes are stamped into the rod to ensure proper installation of the cap.

The S54 connecting rods are weight-optimized (+/- 4 grams). Only one set of connecting rods (the same weight class) is available to maintain balance.

The connecting rod bolts must be angle torqued (refer to Repair Instructions and Technical Data). The bolts can not be replaced separately, if damaged; the connecting rod must be replaced (supplied with new bolts).

The S54 connecting rod bearings use end mounted locating tabs.

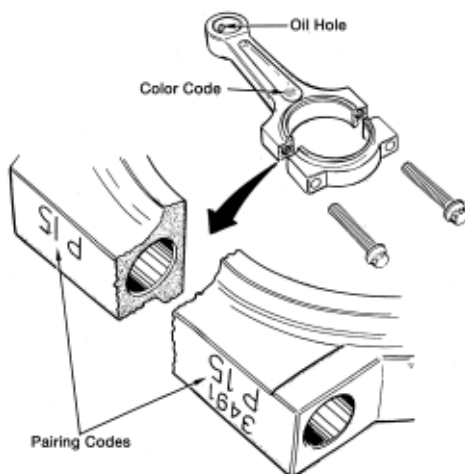

Pistons and Piston Rings

The S54 uses graphite coated cast aluminum (full slipper skirt) pistons with valve recesses.

The piston diameter is 86.965 mm, weighs approximately 470 grams with a compression ratio of 11.5:1.

Install the pistons with the arrow pointing towards the front of the engine.

A Special Tool (ring compressor) is required to install the pistons.

The pistons are cooled by oil spray nozzles that are bolted into the crankcase.

The nozzles are “tapped” into the main oil gallery and delivers a constant oil spray to the underside of the pistons.

The wrist pins are 21 mm in diameter and have tapered ends (inside diameter) for weight reduction.

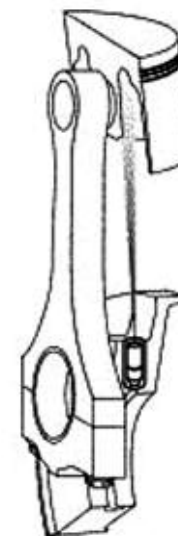
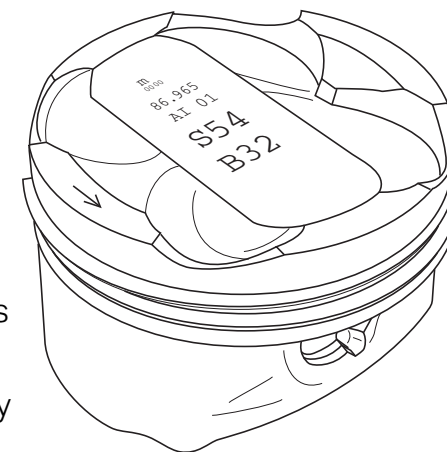

Oil Pump

The S54 oil pump is two stage, supply and scavenge. The pump is driven by the crankshaft with a single row chain.

The oil pump has two separate chambers, the scavenge chamber (1) draws oil from the pickup at the front of the oil pan. The oil is transferred from the pump through a small pipe to the main sump at the rear of the oil pan (2).

The supply chamber (3) draws oil from the main sump through a large pipe (4) to supply oil to the main gallery. The main gallery circuit returns to the pump housing which contains the oil pressure control piston.

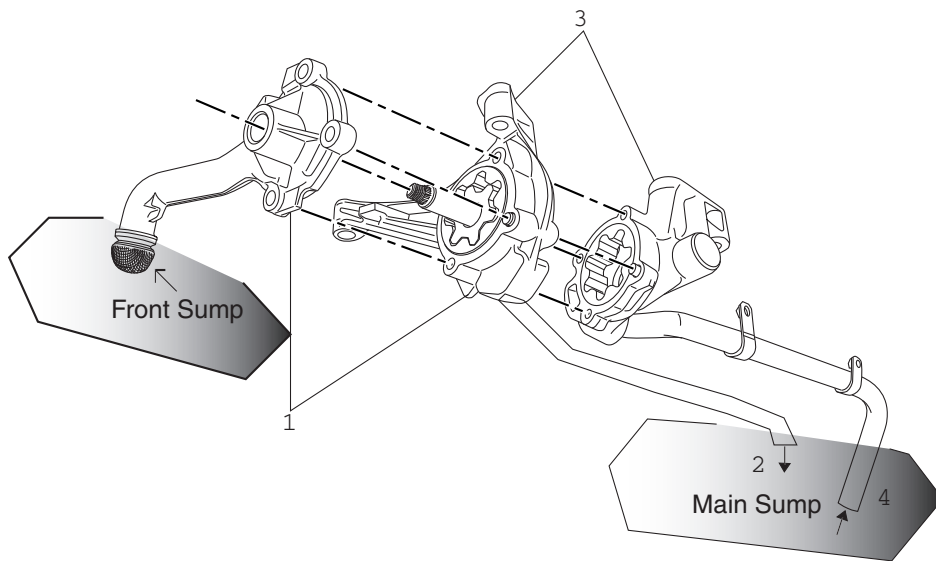

Testing Oil Pressure

The oil pressure is tested at the oil filter housing using the Special Tool #90 88 6 114 390 (adapting retainer bolt and pressure gauge as shown in the Repair Instructions).

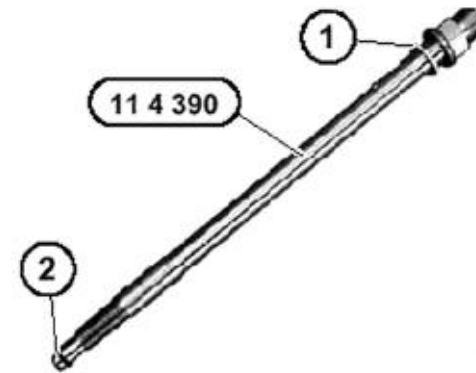

The adapter retainer bolt replaces the oil filter housing cover retaining bolt and provides an adapter fitting for the oil pressure gauge.



Crankcase Ventilation

The S54 features a non-pressurized sealed crankcase ventilation system for the blow-by vapors.

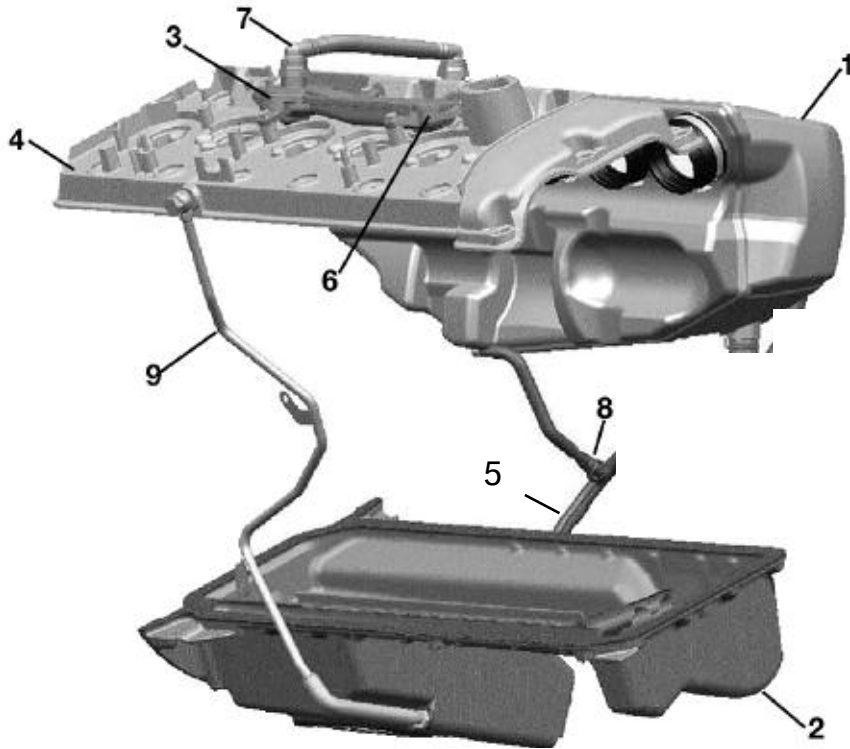

The crankcase blow-by vapors are “purged” by intake manifold vacuum. The vapors are drawn from the cylinder head cover (4) through the inlet of the Oil Separator (6). The Labyrinth (3) separates the oil from the vapors, and the condensate (oil) returns to the oil pan through the return line (9). The vapors exit the Oil Separator through the outlet hose (7) to the intake manifold to be inducted into the combustion chambers.

When the engine is running, intake manifold vacuum will close the Check Valve in the return line (8). When the engine is not running, the Check Valve will open. This allows any condensation (oil) that have collected in the intake manifold to drain back to the oil pan through the dipstick tube.

The cylinder head cover is sealed by a perimeter seal, spark plug port seals and sealing washers under the retaining bolts.

These individual seals must all be properly installed to prevent oil and vacuum leaks.

Index	Explanation	Index	Explanation
1	Intake Manifold	6	Crankcase Vapor Inlet
2	Oil Pan	7	Crankcase Vapor Outlet (To Intake Manifold)
3	Oil Separator (Labyrinth)	8	Condensate Return to Oil Pan (With Check Valve)
4	Cylinder Head Cover	9	Condensate Return To Oil Pan
5	drain back Tube		

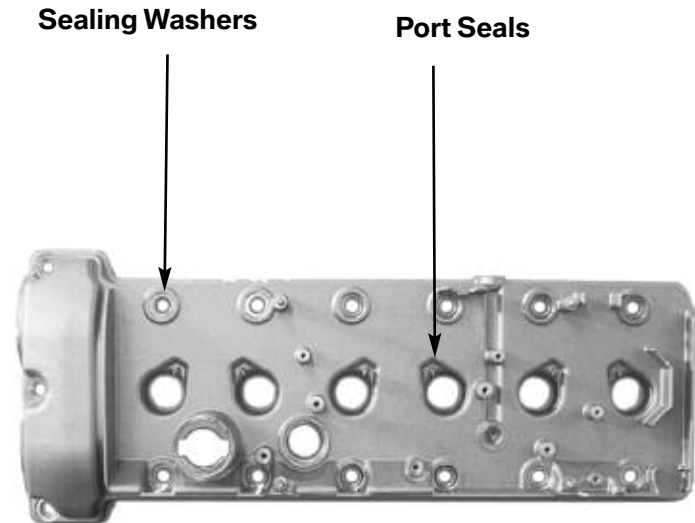

Cylinder Head

The S54 features an aluminum cross-flow cylinder head that houses the camshafts and valve train (one piece).

The combustion chamber reveals the 4 valve per cylinder arrangement and the optimized (flow enhanced) intake and exhaust ports. The spark plugs are centrally located in the combustion area for the most effective power and reduced emission outputs.

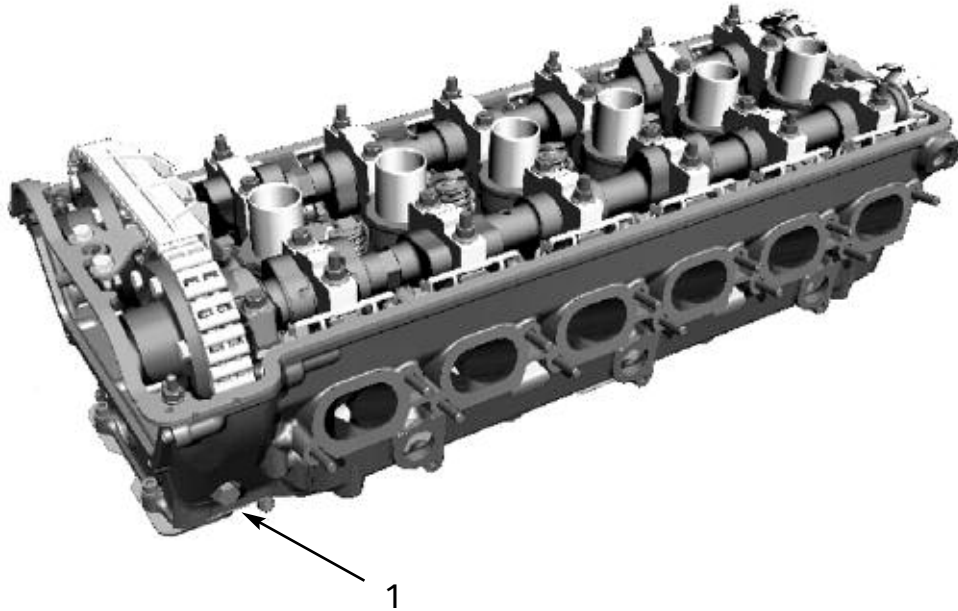

To remove the cylinder head, the camshafts must first be removed to access the cylinder head bolts (refer to the Repair Instructions). The timing chain guide rail bolt (1) must also be removed (see below) and the special sealing washer must be replaced.

To pressure test the cylinder head, a new Special Tool (Pressure Tester Adapter Kit) is required.

Note: Cylinder head machining is not permitted.

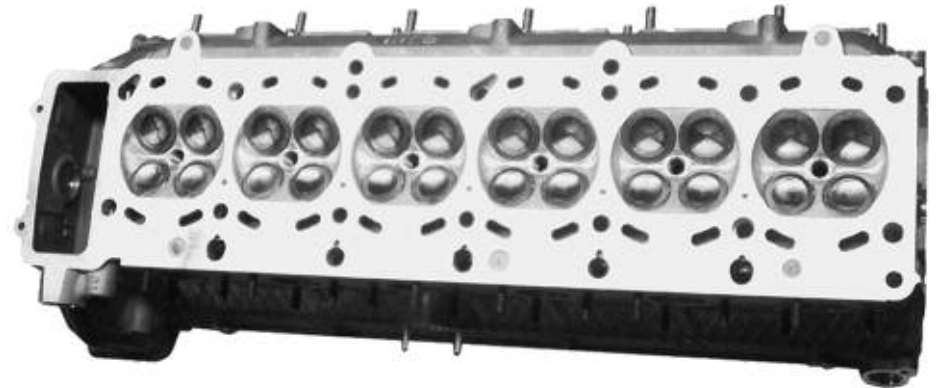

Camshaft Drive

The camshafts are driven by the crankshaft using a double-roller timing chain.

The chain is routed from the crankshaft over a guide rail to the intake and exhaust camshaft sprockets. A two piece hydraulically tensioned guide rail lubricates (three oil holes) and “self adjusts” the chain.

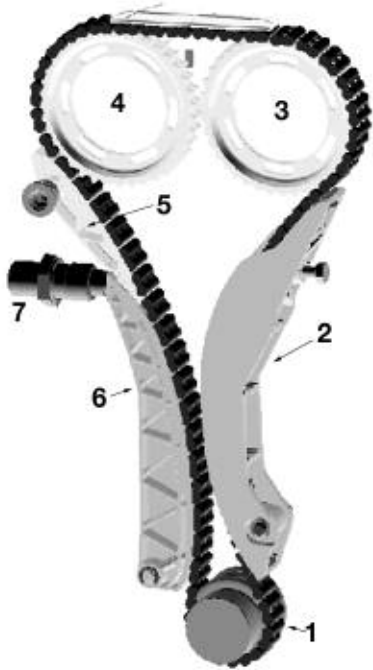

Index	Explanation	Index	Explanation
1	Crankshaft Sprocket	5	Short Tension Rail
2	Aluminum Guide Rail	6	Long Tension Rail (with 3 lubrication Holes)
3	Intake Camshaft Sprocket	7	Hydraulic Tensioner
4	Exhaust Camshaft Sprocket		

Camshafts

The S54 cast iron overhead camshafts are hollow and are strengthened by heat treating the journals and cam lobes. The duration and lift (12 mm) of the lobes are the same on both camshafts.

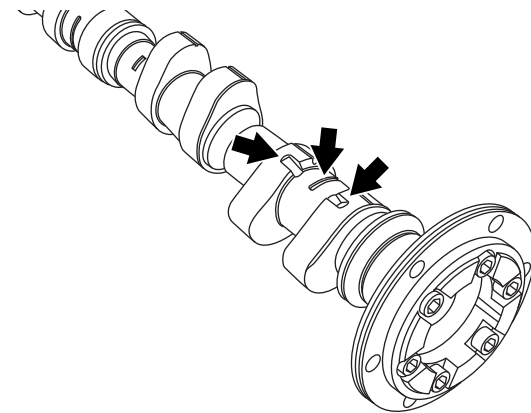

The camshafts are not interchangeable, therefore they should be marked before disassembly.

The camshaft lobes have oil grooves that provide lubrication from the camshaft journals to the lobes and the valve fingers.

The camshafts must be removed and installed with the press fixture (Special Tool as shown in the Repair Instructions).

The camshafts are “timed” with the bridged location tool (pinned into camshaft as shown in the Repair Instructions).

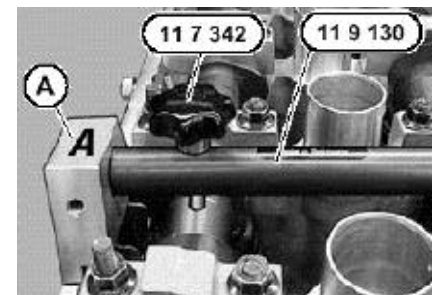
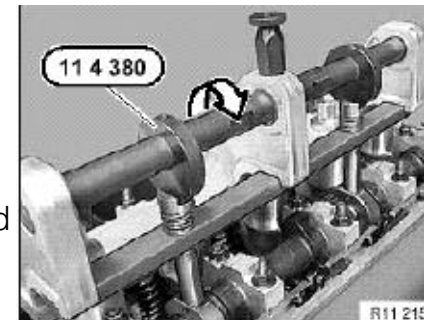

The first camshaft bearing journal also serves as the thrust bearing (unmarked).

This two-piece bearing flange is forged to support VANOS axial loads.

The thrust bearing flange is bolted to the face of the cylinder head. This component is not separately available because the journals are machined with the cylinder head.

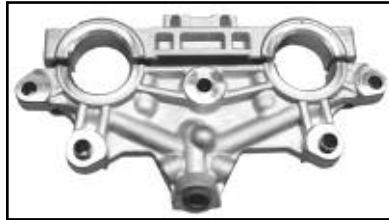

Valve Train

The camshaft lobe actuates the valve finger (rocker arm) which rotates on a finger (rocker) shaft. The valve finger is secured by a spring clip and contacts the valve clearance shim (9 mm diameter) to open the valve.

The adjustable valve clearance set by various shim thickness is:

- Intake 0.18 - 0.23mm
- Exhaust 0.28 - 0.33mm

Note: Set With Engine Temperature < 35° C/95°F

Two feeler gages and a holder with a magnetic tip (Special Tools) are required to adjust the valve clearance. The cam lobe must be rotated away from the valve finger for maximum clearance.

To access the valve clearance shim, remove the finger securing clip. Slide the finger away from the valve spring to expose the shim. Use the magnetic tip holder to extract the shim.

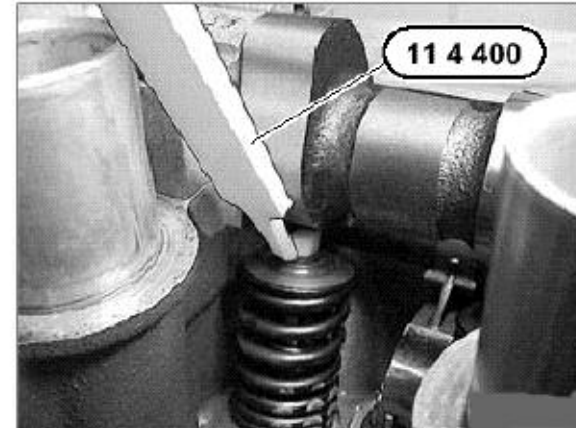

The shims (arrow) are available in sizes from 1.72 to 2.52 mm at 0.04 mm increments

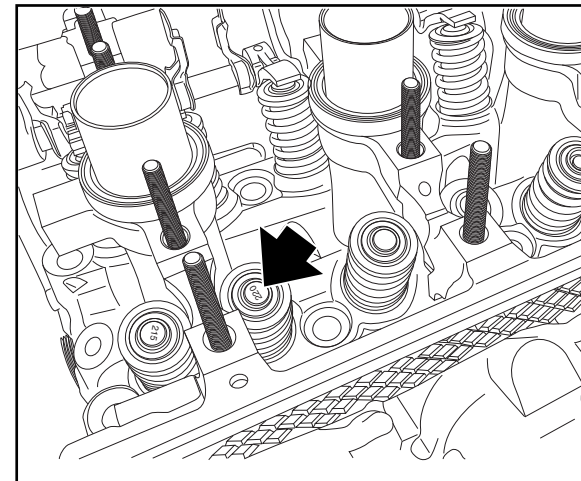

The finger (rocker) shafts are secured with locating bolts (one per side) at the back of the cylinder head (1).

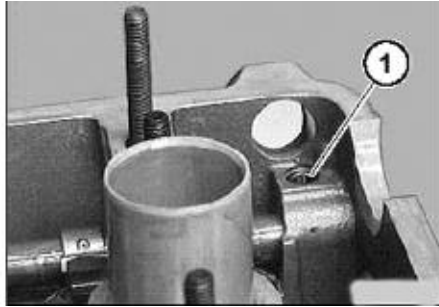

Remove the threaded access bolts (1) from the rear face of the cylinder head and push the shafts through.

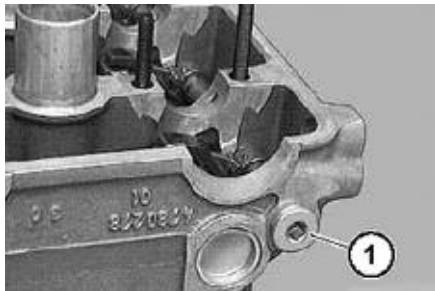

Both finger shafts are hollow, the exhaust shaft is unique because it supplies oil to the cam-shaft bearing journals.

The exhaust shaft receives oil from the main oil gallery through the transfer hole (arrow).

The intake camshaft is lubricated directly from the main oil gallery.



The valve fingers are identical but must be marked for location when previously used.

Lubrication for the slide contact is provided from the camshafts (lobe grooves) and an inlet hole (arrow) allows lubrication for the finger pivot journal.

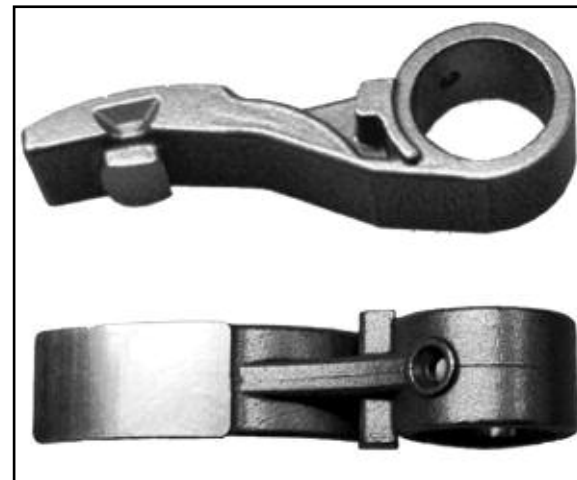

Valves

The intake and exhaust valves are lightweight in design to reduce reciprocating mass.

The valve specifications are:

- Intake 35 mm
- Exhaust 30.5 mm
- Stem-Intake / Exhaust 6.0 mm

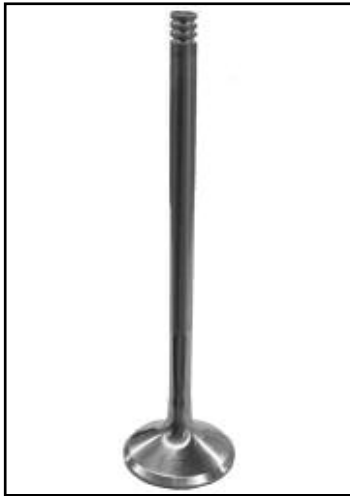

The exhaust valve stems are sodium filled to enhance cooling.

CAUTION!!! Consult the Repair Instructions before performing any repairs and for proper disposal of sodium filled valves.

Valve Springs

The valve spring assembly consists of two progressive wound valve springs.

The springs are marked for correct installation due to progressive winding (paint stripes facing down towards cylinder head).

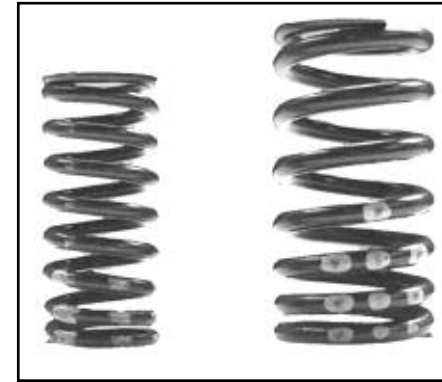

VANOS

Performance, torque, idle characteristics and exhaust emissions reduction are improved by variable camshaft timing (VANOS).

The S54 engine uses double VANOS to adjust the spread angles of the intake and exhaust camshafts.

This system uses a high pressure (100 Bar) control system that ensures responsive and accurate camshaft adjustments to meet the high performance requirements of the M3.

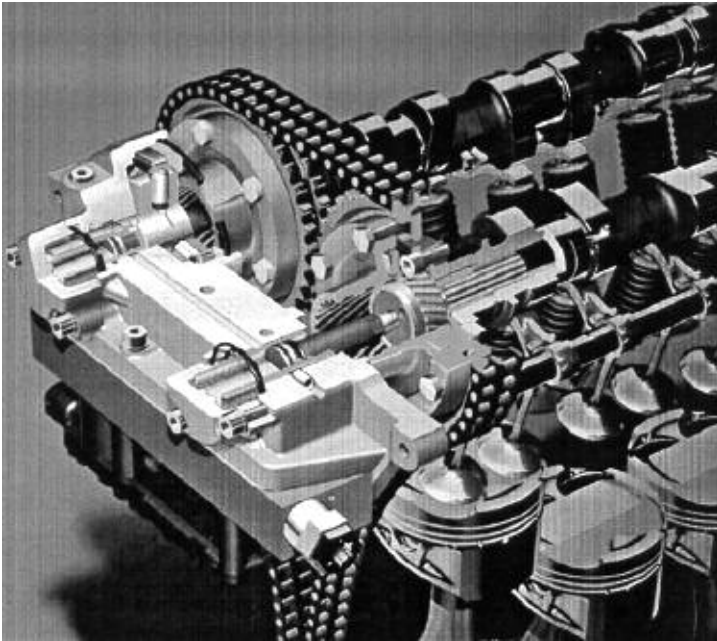

VANOS Unit

The Vanos unit is mounted directly on the front of the cylinder head.

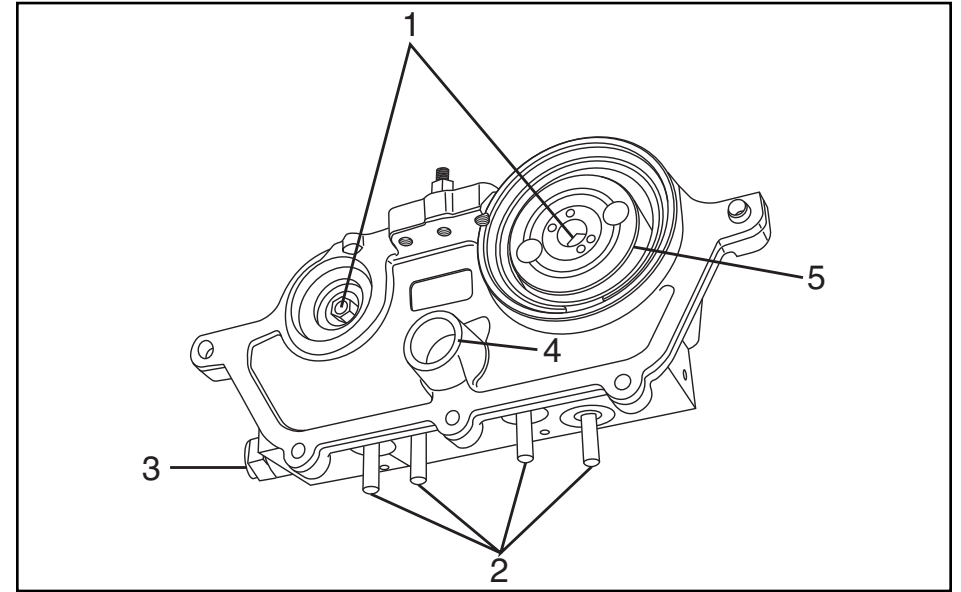

The VANOS unit contains the hydraulically actuated mechanical drives (1), the electronically controlled oil pressure regulating solenoids (2) and the 100 Bar pressure regulating valve (3).

The view of the VANOS unit shows the inlet oil supply pressure reducing valve (4) and the radial piston high pressure output pump driven by the exhaust camshaft (5).

The VANOS solenoid electrical assembly (re-moved from the VANOS unit) contains four solenoids.

Two solenoids are required for each adjusting piston circuit, one for advancing and one for retarding the camshaft timing. The solenoids are controlled by the DME (ECM).

The adjustment shafts contain two sets of splines. The straight splines engage with the camshaft sleeves and the helical spline engage with the chain driven cam sprocket.



The camshaft sleeves are bolted to the end of the camshafts and engage with the straight spline of the adjustment shaft shown above.

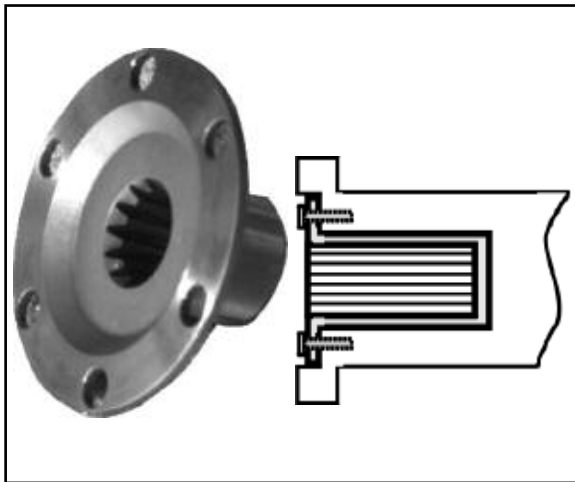

The chain driven sprocket and spacer sleeve assembly is shown to the right (one assembly per camshaft). The sprocket engages with the helical splines of the adjustment shaft.

The exhaust sprocket assembly has two drive “lugs” that must be aligned with the radial piston pump during installation.

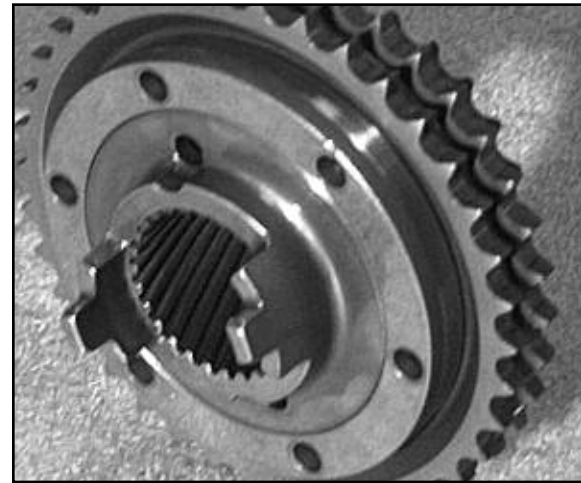

VANOS mechanical operation is dependent on oil pressure applied to position the control pistons. The double VANOS camshafts are infinitely adjustable within the mechanical travel limits of the drive gears.

When oil pressure is applied to the control piston, the piston moves causing the splined adjustment shaft to move. The straight splines slide within the camshaft sleeve. The helical splines rotate the camshaft drive sprocket changing the position in relation to the camshaft position which advances/retards the camshaft timing.

The default (mechanical stop) camshaft position without VANOS influence is:

- Intake Camshaft = Retarded (130° spread angle)
- Exhaust Camshaft = Advance (83° spread angle)

The VANOS enhanced camshaft spread angles are:

- Intake 70 - 130
- Exhaust 83 - 128

The total adjustment range of the camshafts are 60° for the intake and 45° for the exhaust.

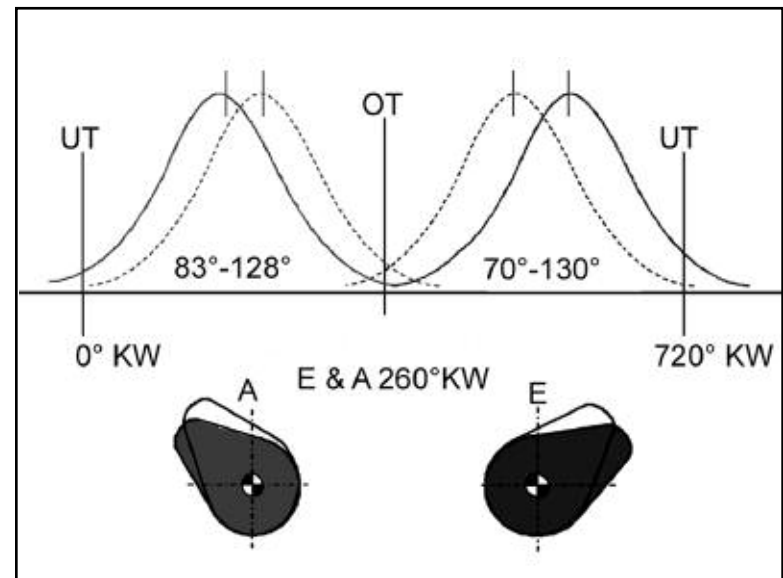
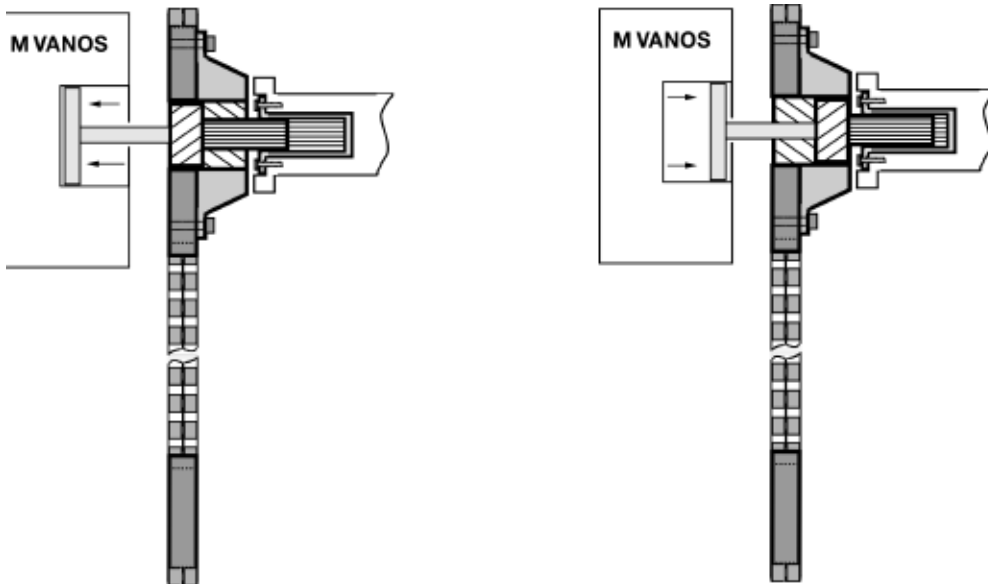

Oil is supplied from main gallery through the front of cylinder head (arrow) to the inlet pressure reducing valve.

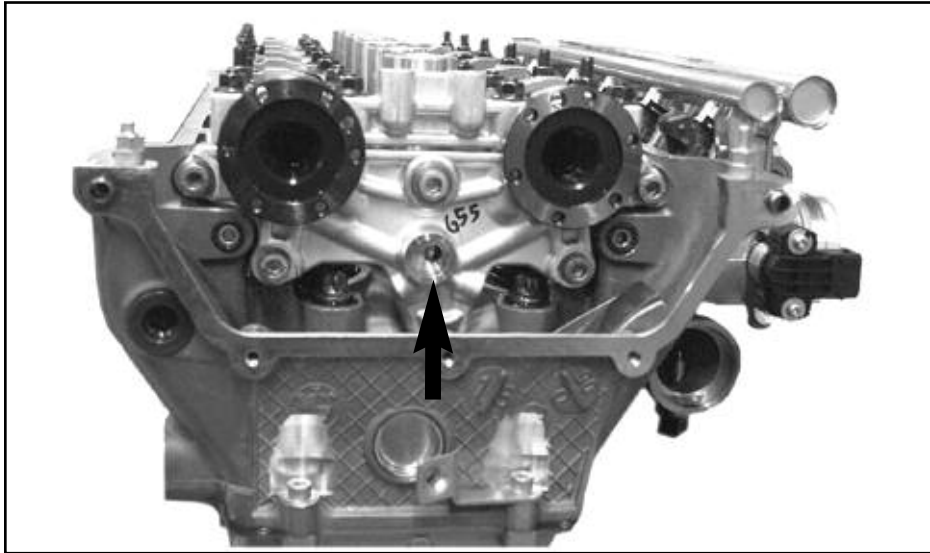

The pressure reducing valve supplies oil to the radial piston high pressure pump. It is located between the cylinder head and the VANOS unit.

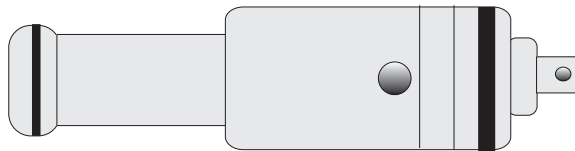

The valve ensures the oil pressure supply to the VANOS pump is 0.5 Bar regardless of the varying pressure from the main oil pressure gallery. The pressure reducing valve is pressed into the VANOS unit and secured by an “o-ring”.

The 100 Bar pressure regulating valve is mounted in the VANOS unit. This valve regulates the pressure produced by the radial piston high pressure pump.

Note: The 100 Bar pressure regulating valve is NOT adjustable.

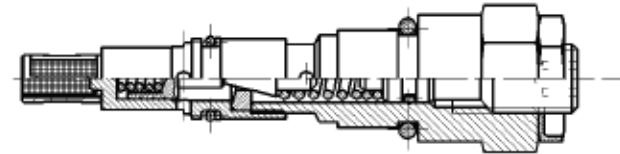

The 100 Bar pressure accumulator ensures that there is a sufficient volume of oil under pressure to adjust the camshafts under all engine operating conditions.

The accumulator is Nitrogen charged and is located on the exhaust side of the engine behind the A/C compressor. It is connected to the VANOS unit by a high pressure line.

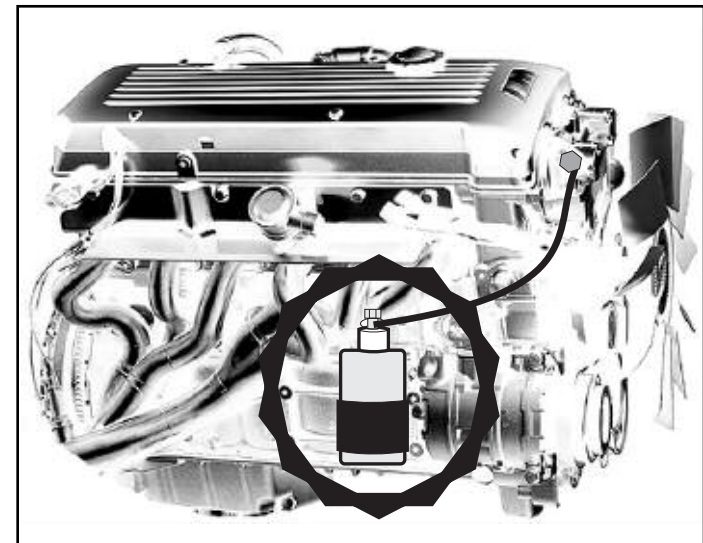

VANOS Hydraulic System

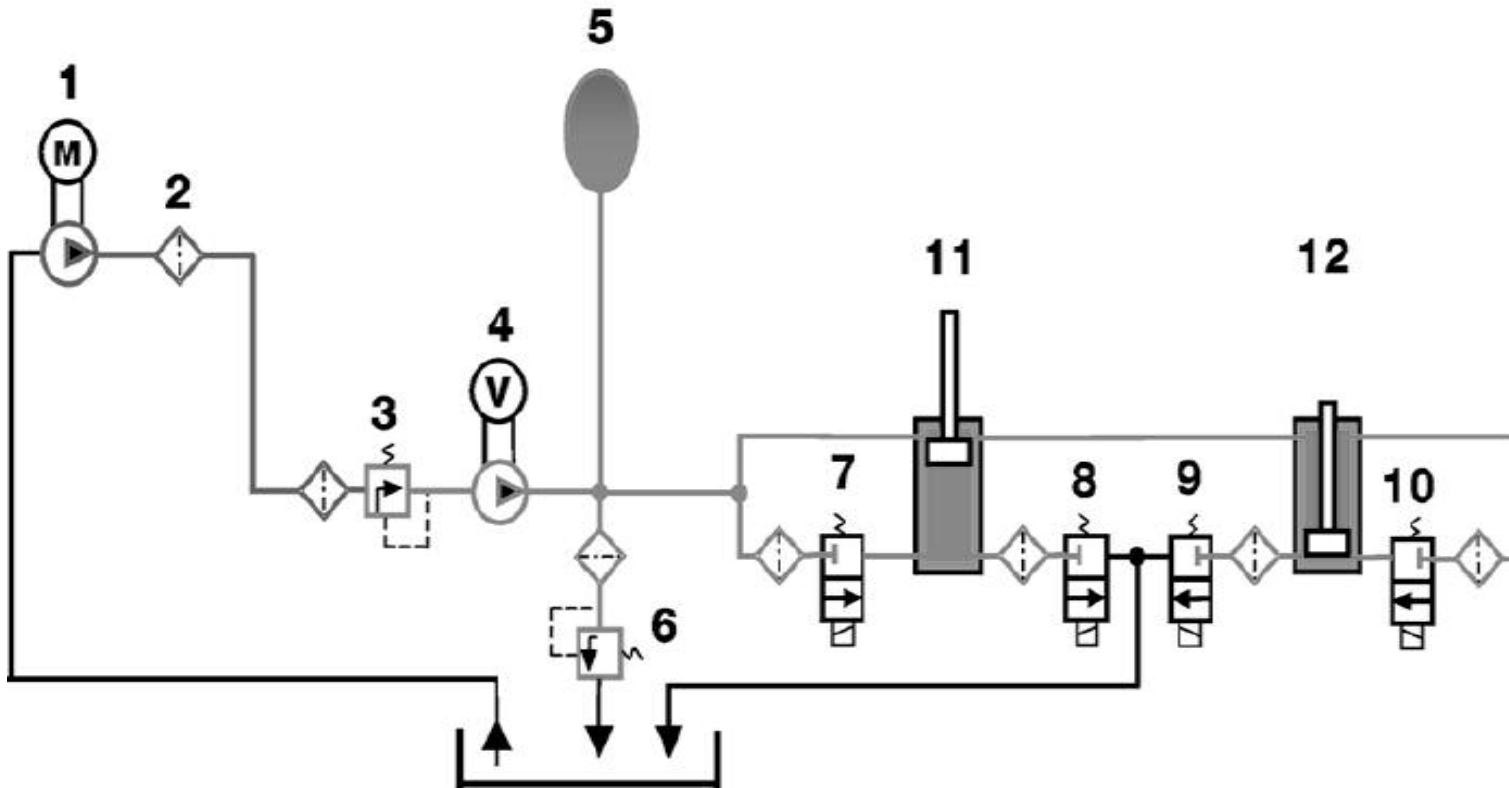

Index	Explanation	Index	Explanation
1	Engine Oil Pump	7	Exhaust Camshaft Inlet Solenoid Valve
2	Engine Oil Filter	8	Exhaust Camshaft Outlet Solenoid Valve
3	Pressure Reducing Valve (0.5 Bar)	9	Intake Camshaft Outlet Solenoid Valve
4	VANOS Oil Pump	10	Intake Camshaft Inlet Solenoid Valve
5	VANOS Accumulator	11	Exhaust Camshaft Control Piston (Advance)
6	100 Bar Pressure Regulating Valve	12	Intake Camshaft Control Piston (Retard)

VANOS system hydraulic operation:

- When the engine starts, oil from the main engine oil pump is fed under pressure to the pressure reducing valve.
- The oil pressure is dropped to approximately 0.5 Bar and fed to the radial piston high pressure oil pump.
- The pump is driven by the exhaust camshaft and the 100 Bar pressure is built up by the pressure regulating valve. The volume of pressurized oil is stored in the accumulator supplying both adjustment pistons. Both pistons are held in the default position by the high pressure oil.
- At the same time the high pressure oil is available at the inlet solenoids of both adjustment pistons.
- VANOS adjustment is carried out by the ECM pulsing the inlet and outlet solenoids to allow pressurized oil to the back side of the adjustment pistons. The surface area on this side of the piston is larger so that the oil pressure is greater and the adjustment piston will move causing the valve timing to change.
- The piston is connected to the adjustment shaft. As the piston moves, the shaft turns the helical splines varying the camshaft sprocket position in relation to the camshafts.

CAUTION!!!

The VANOS system is under high pressure (100 Bar). Always consult the Repair Instructions before performing any repairs.

Workshop Hints

When installing the intake camshaft, a visual “sight” is the cam lobes on cylinder number 1 should be pointing horizontally inwards (as shown on the right).

When installing the exhaust camshaft, the cam lobes for cylinder number 1 should be pointing horizontally inwards (refer to Repair Instructions for detailed graphics).

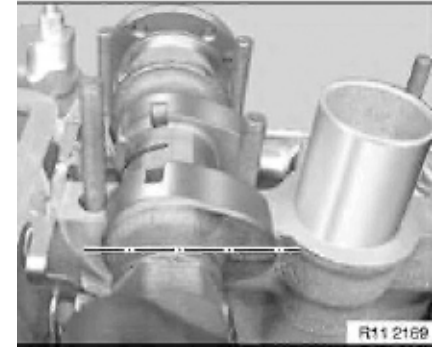

The VANOS function test can be performed by using Special Tools:

- #90 88 6 126 411
- #90 88 6 126 050
- Regulated Compressed Air (2-8 bar)

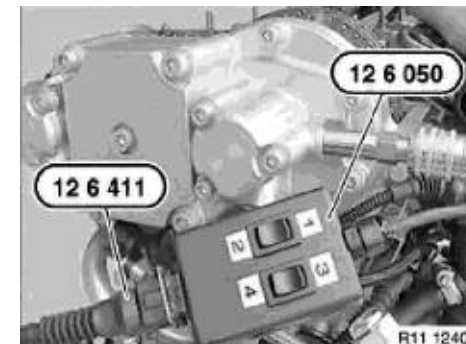

Note: Refer to the Repair Instructions for the VANOS function test procedures.

Intake Air Plenum

The intake air plenum is designed for maximum volume required for the S54 engine. The air filter housing and intake manifold are different on the M roadster and M coupe as compared with the M3 due to the under hood dimensions.

The flow characteristics of the one-piece plastic shell is enhanced by internal “funnel” cones to direct the intake air to the throttle housings.

The plenum is attached to the throttle housings by rubber sleeves. A Special Tool (clamp pliers) is required to secure the one-time use clamps.

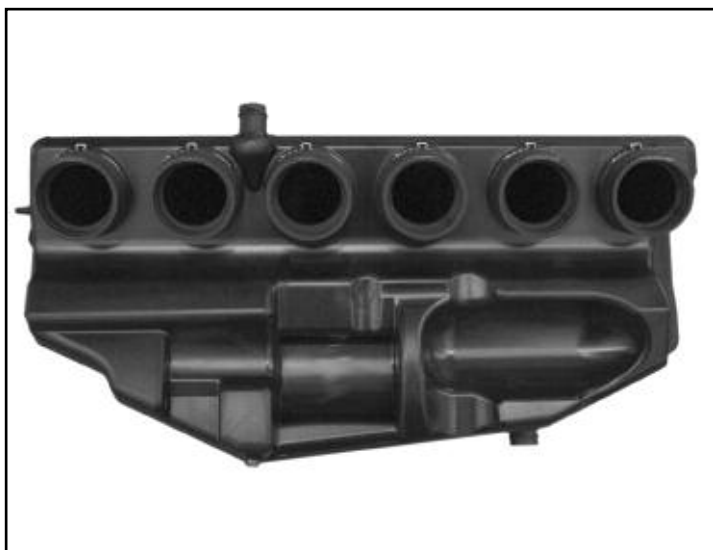

E46 M3 air plenum shown

Intake Air System

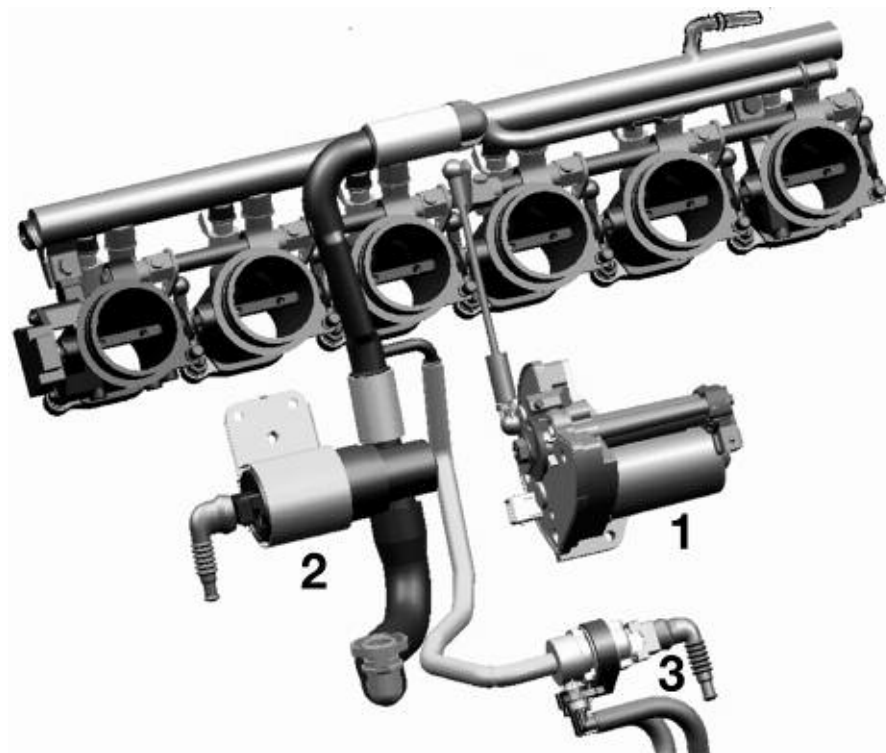

The S54 uses six individual throttle housings operated by an EDR actuator (1 electronic throttle control). For low engine speed (low load) and idling, intake air is provided by an idle air actuator (2). The valve regulates air flow through an external air distribution pipe to the individual throttle housings. Fuel tank vapor intake is regulated by the Evaporative Emission Valve (3).

Note: Refer to the Repair Instructions for the procedure to adjust and synchronize the throttle housings.

Fuel Supply

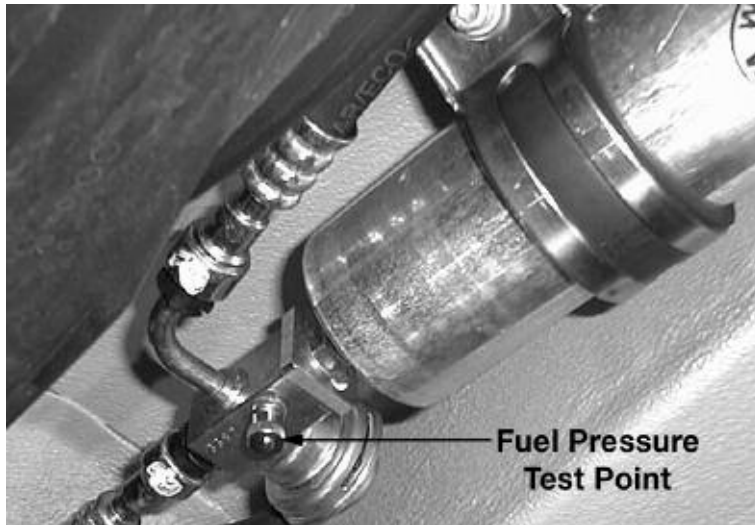

The fuel is supplied through a Non Return Fuel Rail System. This system is used on the S54 for LEV compliancy.

The fuel supply pressure is controlled by the 5 Bar fuel pressure regulator integrated in the fuel filter assembly. The regulator is influenced by engine vacuum via a hose connected to the external air distribution pipe. The fuel exits the fuel pressure regulator supplying the fuel rail and the injectors. The E46 M3 fuel filter assembly is located under the left front floor area (next to the frame rail).

The fuel return line is located on the filter/regulator assembly which directs the unused fuel back to the fuel tank. The fuel tank hydrocarbons are reduced by returning the fuel from this point instead of from the fuel rail.

Clutch Assembly

The S54 clutch assembly is specially designed to transfer the high torque to the driveline and dampen vibrations throughout the rpm range.

The clutch assembly consists of:

- Hydraulically Dampened Dual-Mass Flywheel
- Diaphragm Type Pressure Plate and Drive Disk

Exhaust System

The US S54 uses two high performance stainless steel exhaust manifolds. The catalytic converters are integral with each exhaust manifold.

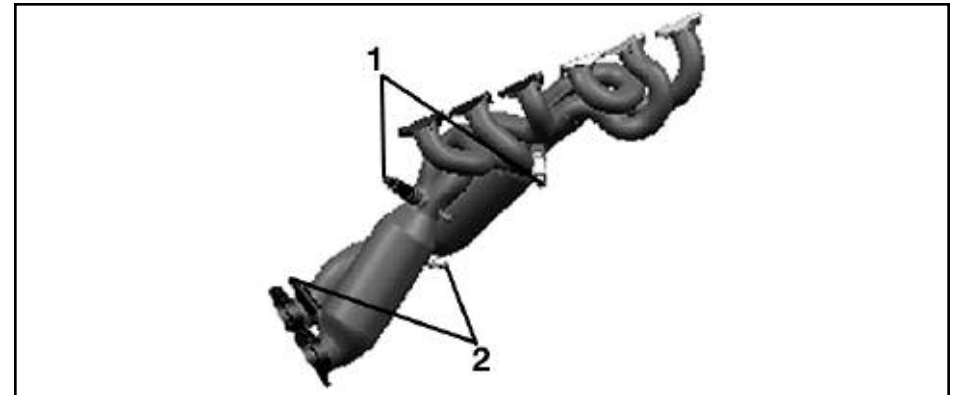

Each exhaust manifold/catalyst contains a pre (1) and post (2) oxygen sensor. The sensors require a Special Tool (crescent wrench with swivel adapter) for removal.

The E46 M3 exhaust system is a dual channel up to the muffler. By using the M-mobility kit, additional clearance is provided for the 40 liter half-shell muffler with four outlets. The M roadster and M coupe have separate dual mufflers.



Classroom Exercise - Review Questions

1. What is the valve clearance and at what temperature should it be checked?

Intake _____ Exhaust _____ Engine Temperature _____

2. What does the term “cracked” connecting rod mean?

3. What is the part number of the special tool needed to remove the valve shims on the S54 engine?

4. What is the function(s) of the oil pumps on the S54?

5. Regarding the Crankcase Ventilation System, what is the purpose of the Check Valve in the oil return line from the intake manifold?



Classroom Exercise - Review Questions

6. When installing the camshafts, they should be installed based on what visual sight?

7. What is unique about the exhaust finger (rocker) shaft?

8. What are the two differences between the intake and exhaust valves?

9. What must be “aligned” with the radial piston high pressure pump when installing the VANOS unit?

10. Where is the fuel pressure tested on the E46 M3 and what is the nominal pressure?



Workshop Exercise - Remove and Replace Camshafts

Using an instructor assigned S54 training engine follow the repair instructions for the removal and replacement of the VANOS adjustment unit and the camshafts. Answer the questions and fill in the required information as you work through the exercise.

Fit special tool 11 5 100 to four screws on crankshaft hub.

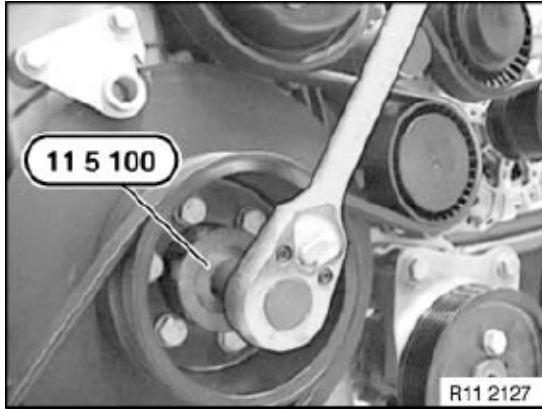

Rotate crankshaft in direction of rotation as far as firing TDC position of 1st cylinder.

Secure vibration damper with special tool 11 2 300 in firing TDC position of 1st cylinder.

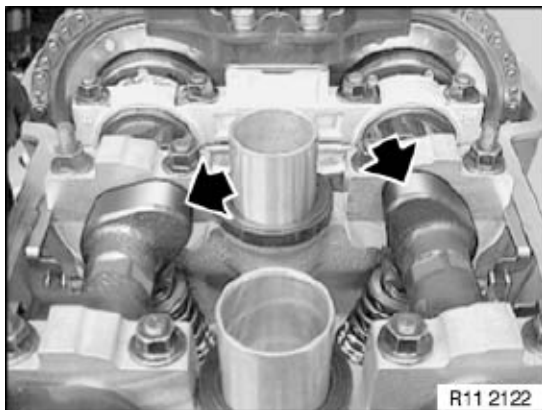
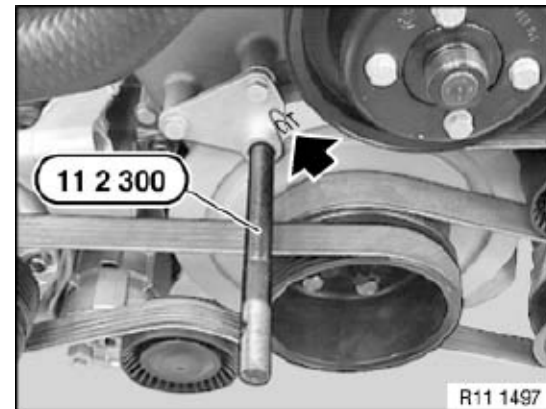

In what position does VANOS set the Intake and Exhaust camshaft to facilitate engine starting?



Workshop Exercise - Remove and Replace Camshafts

Detach the oil line bracket from timing case cover.

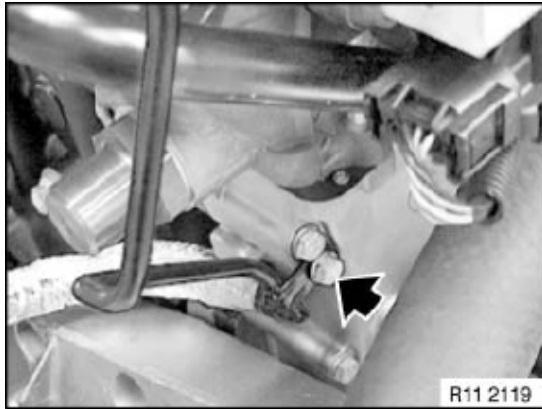

Fit special tool 11 7 130 to VANOS adjustment unit.

Connect compressed air (2 to 8 bar).

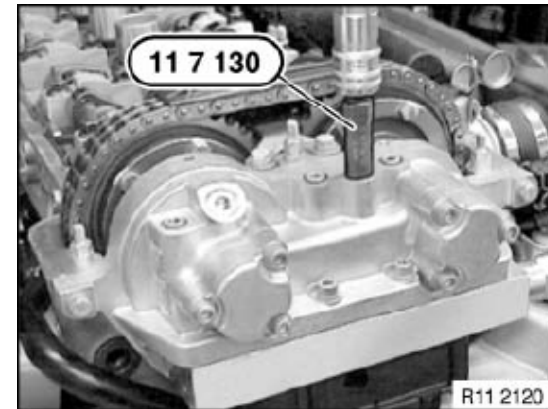

Remove oil line from VANOS adjustment unit.

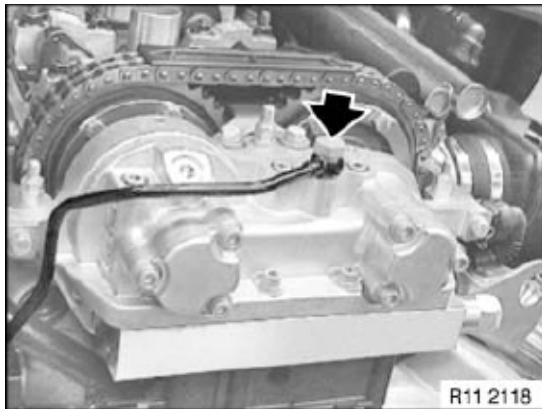

Disconnect plug connection on solenoid valve.

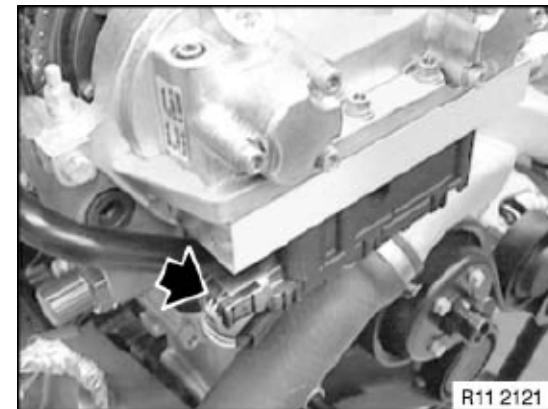



Workshop Exercise - Remove and Replace Camshafts

Connect special tool 12 6 050 in conjunction with special tool 12 6 411 (from special tool kit 12 6 410) to solenoid valves.

Connect special tool 12 6 411 to correct terminals on car battery.

Press and hold down toggle switch button 1 on special tool 12 6 050.

At same time, rotate INTAKE camshaft at hexagon drive against direction of rotation as far as it will go. (See arrow below.)

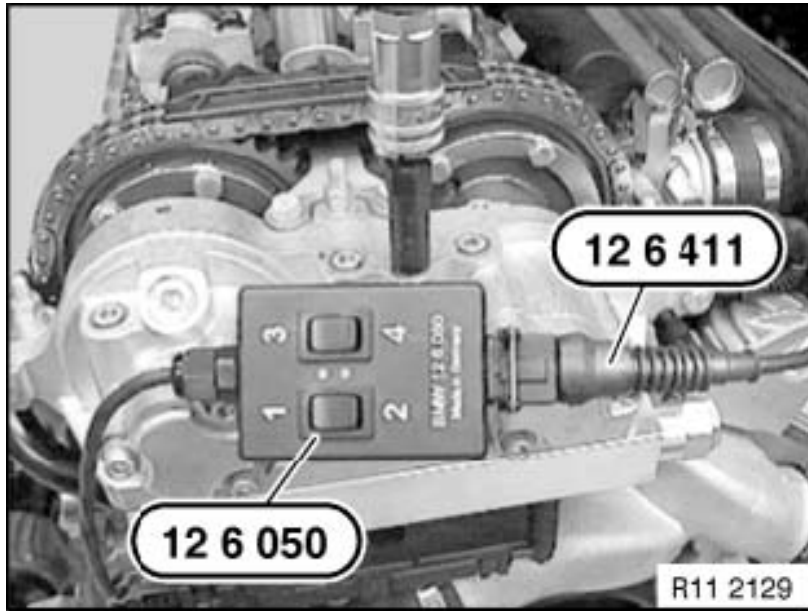

Alternately press toggle switch buttons 1 and 2 several times on special tool 12 6 050.

What is special tool 12 6 050 used for?

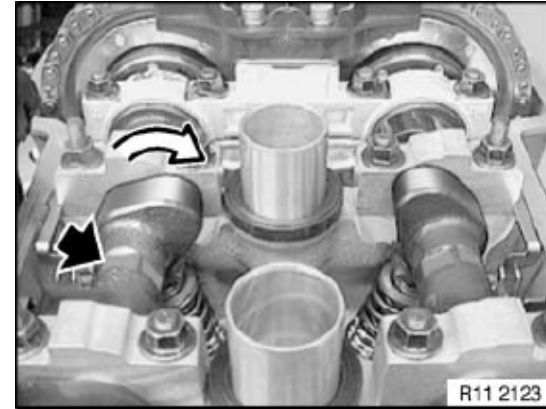

Note: Spline teeth in VANOS gear are engaged; and intake camshaft cannot be rotated further.

What is the purpose for this procedure?



Workshop Exercise - Remove and Replace Camshafts

Alternately press toggle switch buttons 3 and 4 several times on special tool 12 6 050.

Press and hold down toggle switch button 3 on special tool 12 6 050.

At same time, rotate EXHAUST camshaft at hexagon drive against direction of rotation as far as it will go. (See below)

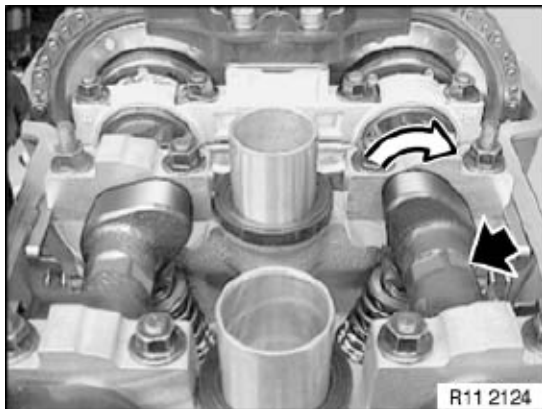

Note: Spline teeth in VANOS gear are engaged; and exhaust camshaft cannot be rotated further.

Disconnect compressed air and remove special tool 11 7 130 from the VANOS unit.

Remove bolts 1 and 3 and remove sliding rail 2 and holder 4. (See below)

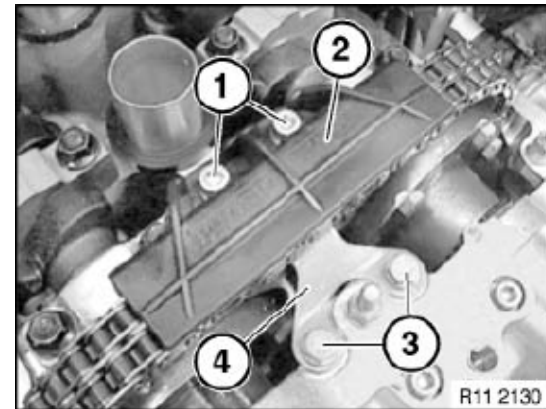

Remove special tool 11 2 300. Rotate crankshaft in direction of rotation a further revolution up to the overlap TDC position and align the O/T marking on the vibration damper with the pointer. (See below)

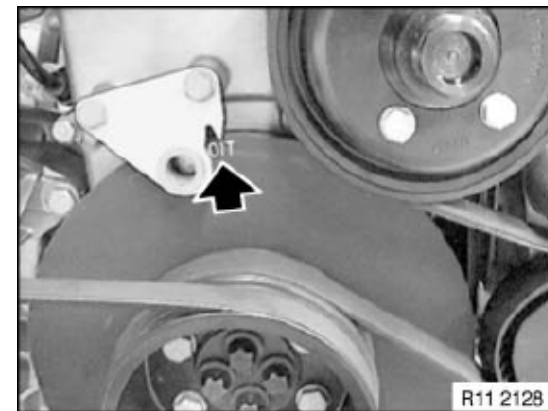



Workshop Exercise - Remove and Replace Camshafts

Loosen the six accessible bolts on the VANOS gears two full turns.

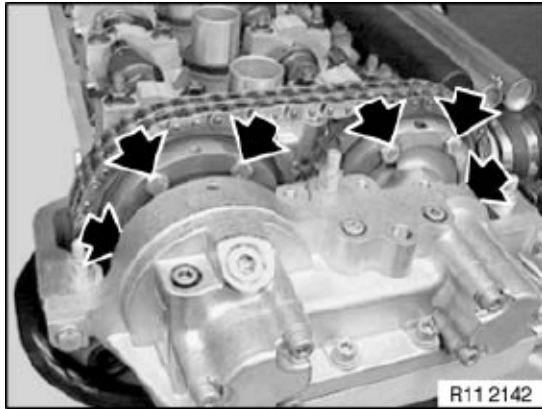

Loosen the remaining six bolts on the VANOS gears two full turns.

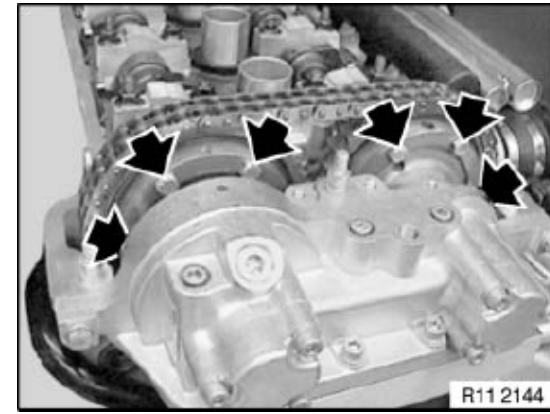

Rotate the engine at central bolt in direction of rotation until #1 cylinder is at TDC firing position. Secure vibration damper in position with special tool 11 2 300.

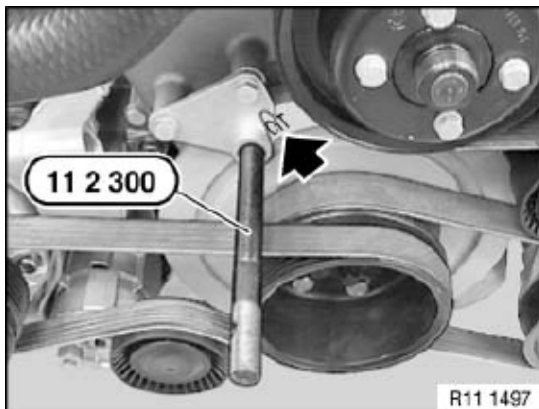

Release screws on VANOS adjustment unit.

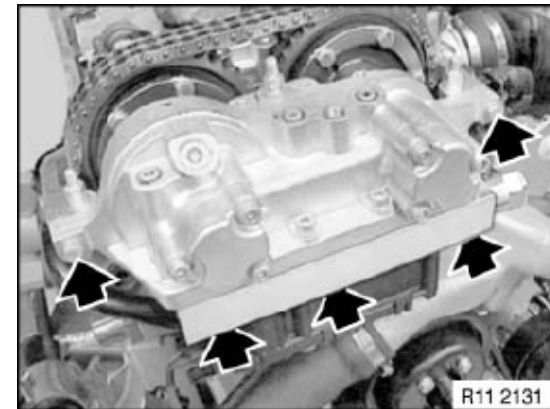

Carefully remove the VANOS adjustment unit and set aside.



Workshop Exercise - Remove and Replace Camshafts

Remove the loose bolts on INTAKE side spline hub.

Remove spline hub (1) with plate spring “washer” and supporting ring. (See Caution!)

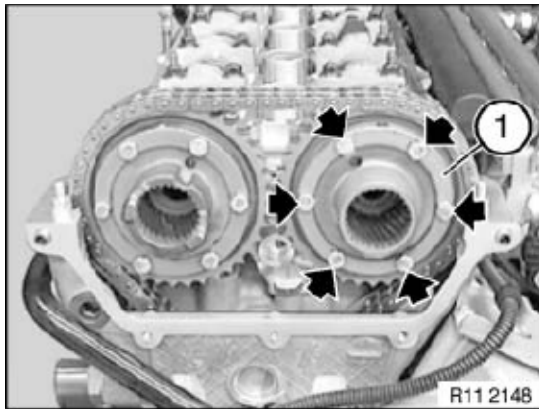

Remove the loose bolts on EXHAUST side spline hub.

Remove spline hub (1) with plate spring “washer” and supporting ring.

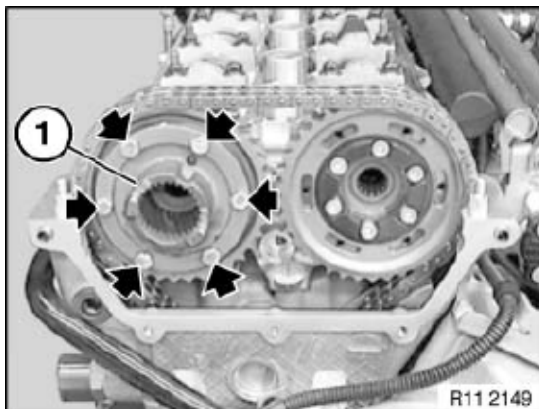

CAUTION!!!

The supporting ring and plate spring “washer” can easily fall out when removed.

Remove chain tensioner.

Detach sprocket wheel (1 and 2) from centering sleeve.

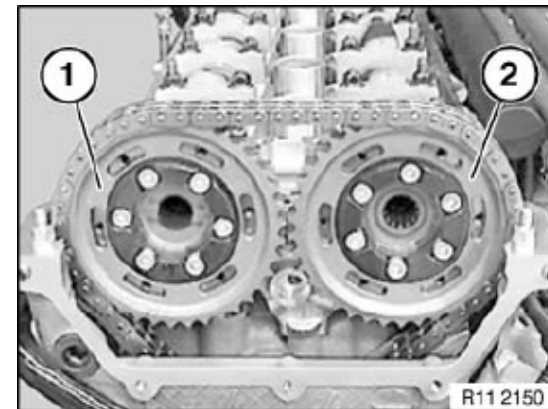

Hold timing chain under tension while removing sprocket wheels (1 and 2).

Then, secure the timing chain to prevent it slipping down into the crankcase.



Workshop Exercise - Remove and Replace Camshafts

Remove special tool 11 2 300

While lifting timing chain, rotate engine at central bolt against direction of rotation to 30° before TDC position.

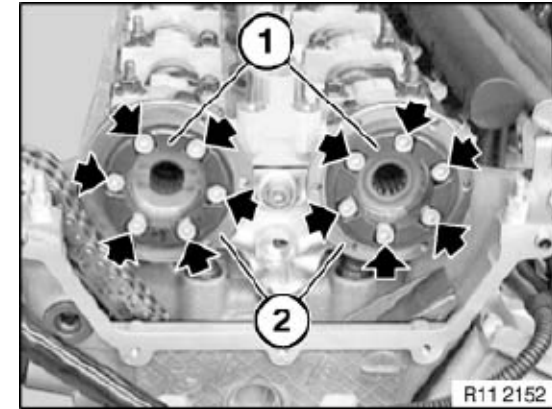
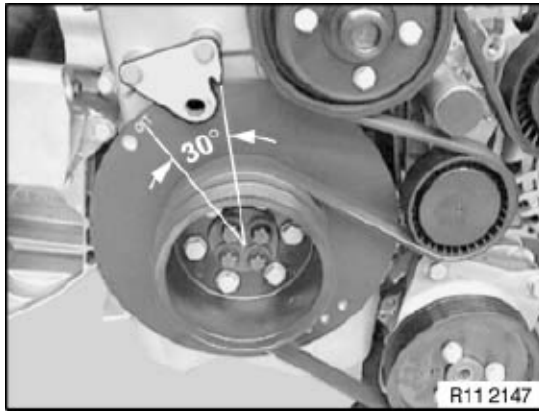

Remove toothed sleeves (3) from EXHAUST and INTAKE camshafts.

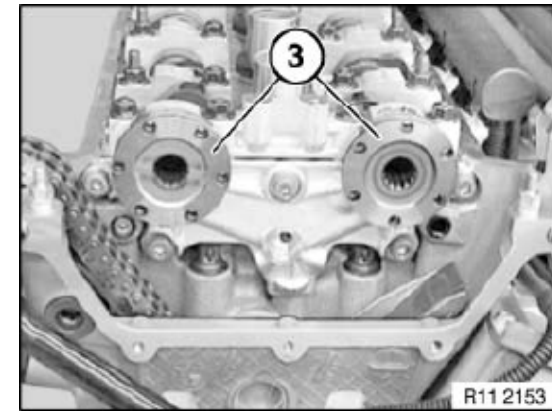

Why is this step important?

Grip camshafts at hexagon head and release bolts on centering sleeves (1).

Remove centering sleeves (1) on EXHAUST and INTAKE sides with thrust washers (2).

When are these last two steps not necessary?



Workshop Exercise - Remove and Replace Camshafts

Release the nuts on the thrust bearing flange (1) and remove.

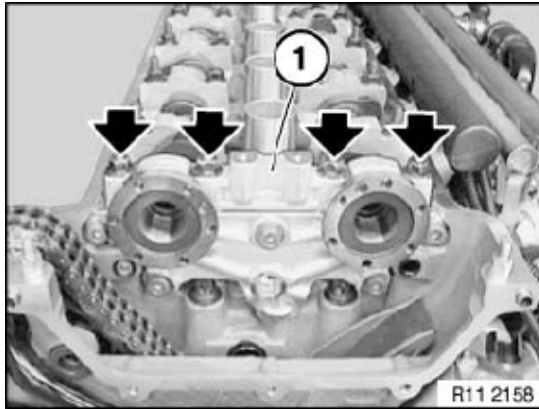

Install special tool 11 4 380 on INTAKE camshaft and screw into spark plug threads of cylinders 2 and 5.

Pretension INTAKE camshaft by rotating eccentric shaft.
Release all nuts of bearing caps on intake camshaft.

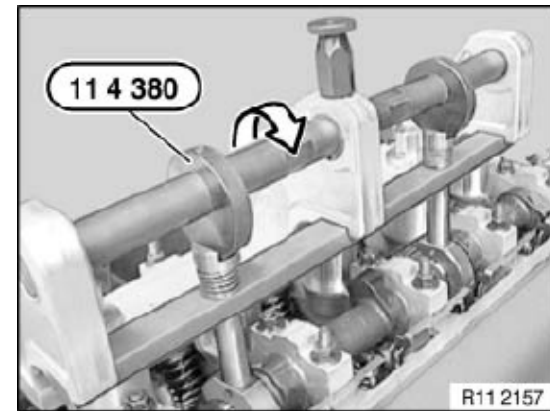

Removing INTAKE camshaft:

Note direction and angle of rotation.

Rotate the INTAKE camshaft at hexagon **inwards** until cylinder #1 cam lobes are horizontal. (See below)

Relieve tension on special tool 11 4 380 and remove.

Lift out intake camshaft and set aside.

What must be kept in mind when releasing the pressure on the camshaft?

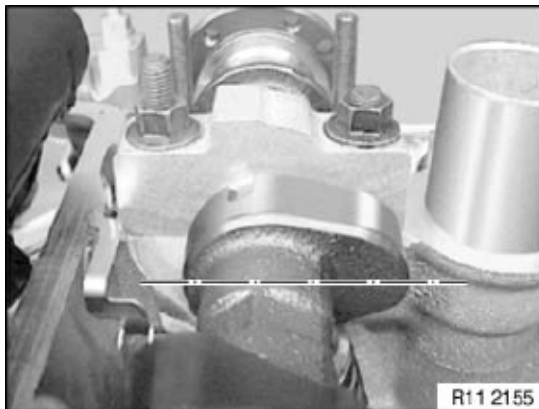



Workshop Exercise - Remove and Replace Camshafts

Removing EXHAUST camshaft:

Note direction and angle of rotation.

Rotate EXHAUST camshaft at hexagon **inwards** until cylinder #1 cam lobes are horizontal. (See below)

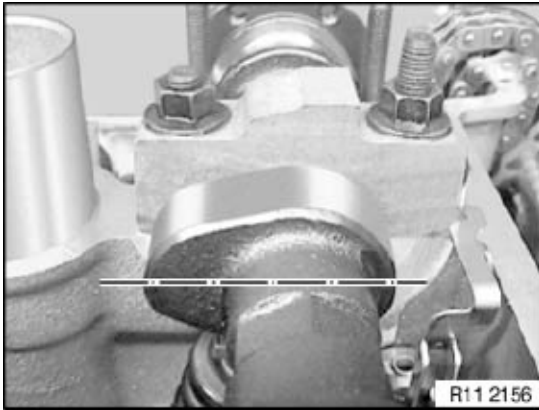

Install special tool 11 4 380 on exhaust camshaft and screw into spark plug threads of cylinders 2 and 5.

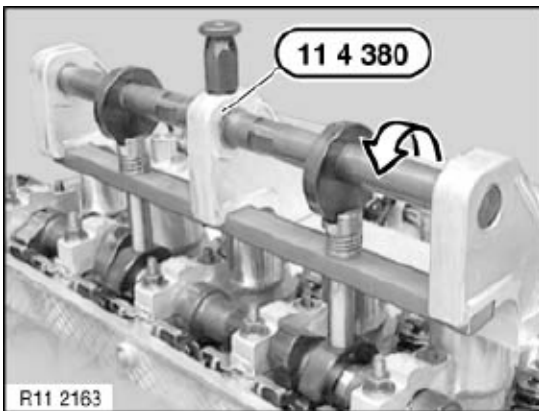

Pretension exhaust camshaft by rotating eccentric shaft.
Release all nuts of bearing caps on exhaust camshaft.

How are the bearing caps marked for both camshafts?

Relieve tension on special tool 11 4 380 and remove.

Lift out exhaust camshaft and set aside.

Inspect both camshafts and identify the markings.
Fill in intake and exhaust in the spaces below.

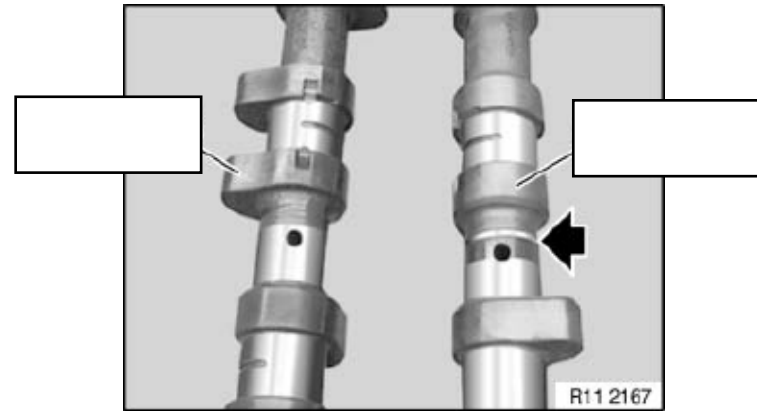

Which camshaft is identified by a groove behind the locating hole?
(See above)



Workshop Exercise - Remove and Replace Camshafts

Identify which signal ring belongs on the INTAKE camshaft and which on the EXHAUST.

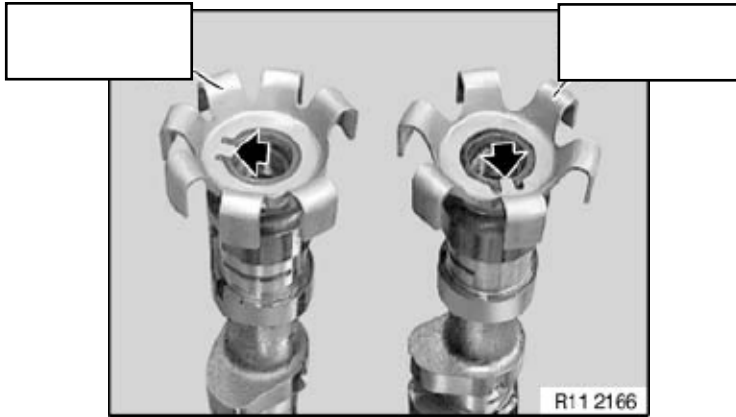

Explain the differences of the signal rings below.

What is the torque specifications for the signal ring bolts?

Installing INTAKE camshaft:

Install INTAKE camshaft in such a way that cam lobes on cylinder #1 point inwards horizontally.

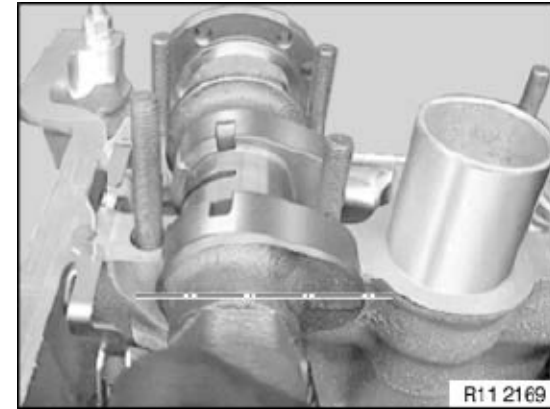

Install special tool 11 4 380 on INTAKE camshaft and screw into spark plug threads of cylinders 2 and 5.

Pretension INTAKE camshaft by rotating eccentric shaft

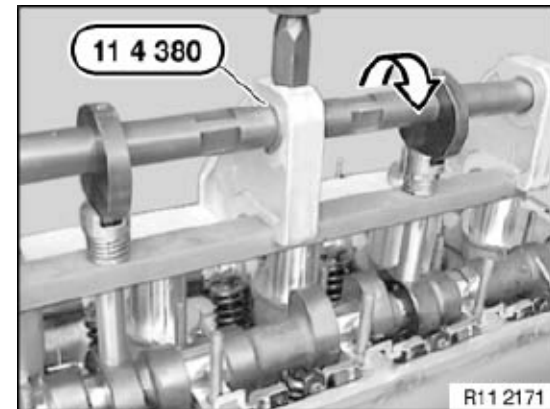



Workshop Exercise - Remove and Replace Camshafts

Install the INTAKE side bearing caps

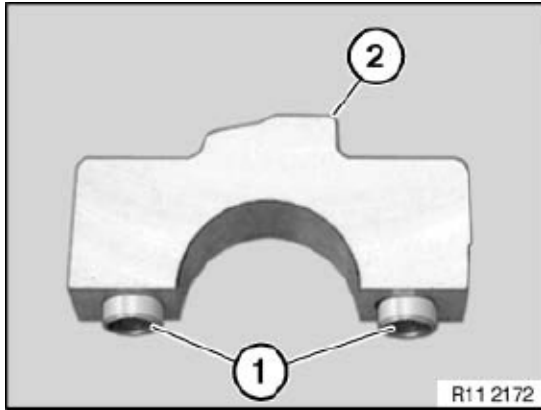

Based on the graphic above, what is the correct installation position of the INTAKE camshaft bearing caps?

What precaution should be observed while installing the bearing caps?

Manually tighten bearing cap nuts and then tighten down from inside to outside in 1/2 turn increments.

Torque bearing cap bolts to specifications and remove special tool 11 4 380.

What is the specified torque for the intake camshaft bearing caps?

Rotate INTAKE camshaft at hexagon from horizontal position upwards until locating hole (1) in camshaft is vertical.

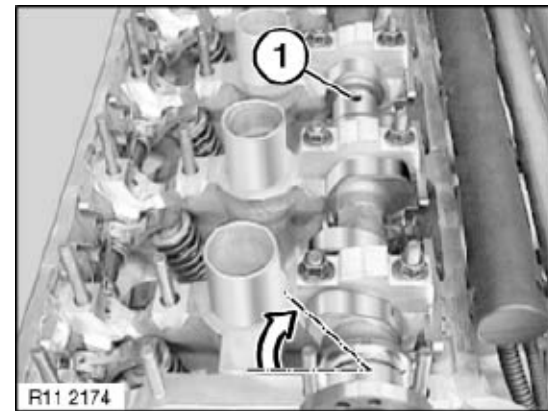



Workshop Exercise - Remove and Replace Camshafts

Attach special tool 11 9 130 to cylinder head.

Align the INTAKE camshaft at hexagon until special tool 11 7 342 can be joined by means of special tool 11 9 130 in locating hole.

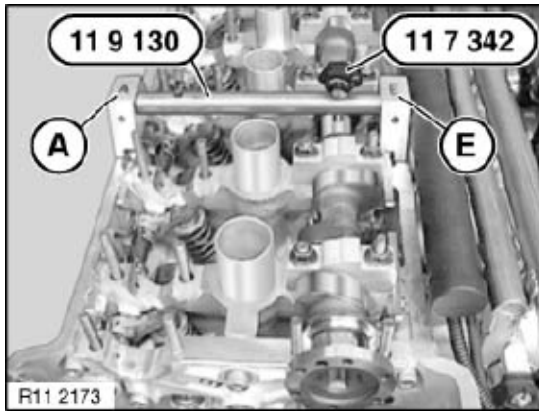

What is important to note regarding the installation of special tool 11 9 130?

Installing EXHAUST camshaft:

Install the EXHAUST camshaft in such a way that cam lobes on cylinder #1 point inwards horizontally.

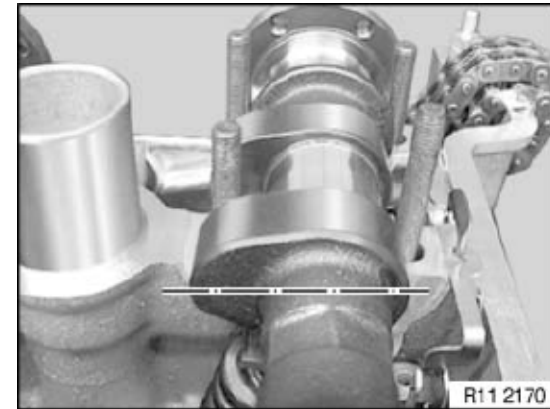

Install special tool 11 4 380 on EXHAUST camshaft and screw into spark plug threads of cylinders 2 and 5.

Pretension exhaust camshaft by rotating eccentric shaft.

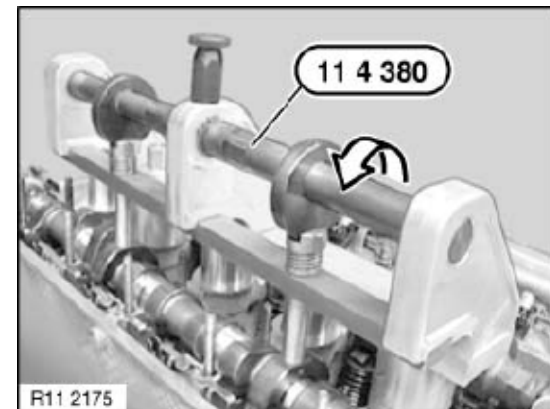



Workshop Exercise - Remove and Replace Camshafts

Install the EXHAUST side camshaft bearing caps.

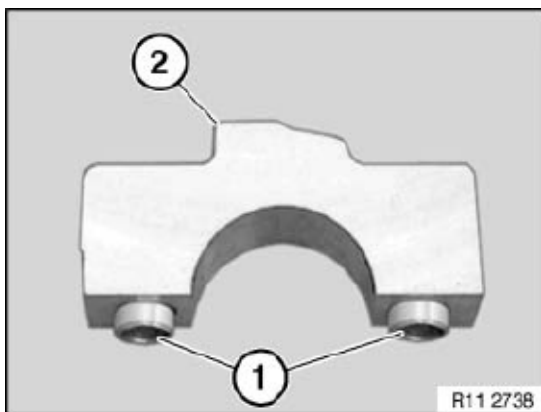

In which position are the EXHAUST camshaft bearing caps installed?

As on the intake, align the EXHAUST camshaft bearing caps by hand until they are secured by means of adapter sleeves.

Manually tighten bearing cap nuts and then tighten down from inside to outside in 1/2 turn increments.

Torque camshaft bearing caps to specifications.

What is the proper torque specification for the EXHAUST camshaft bearing caps?

Remove special tool 11 4 380.

Rotate the EXHAUST camshaft at hexagon from horizontal position upwards until locating hole (1) in camshaft is vertical.

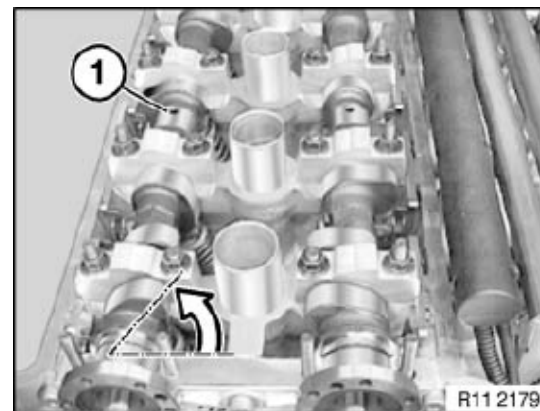

Attach special tool 11 9 130 to cylinder head.

Align exhaust camshaft at hexagon until special tool 11 7 342 can be joined by means of special tool 11 9 130 in locating hole.

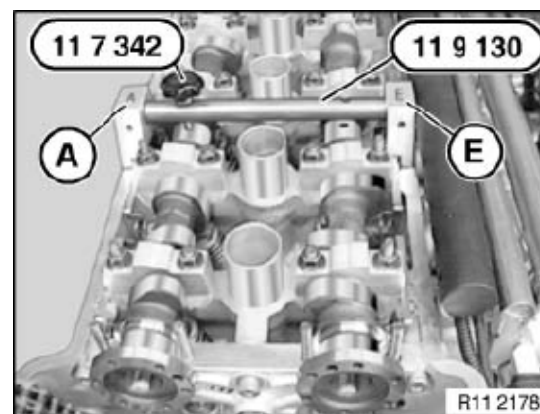

Remove special tool 11 9 130 and special tool 11 7 342.



Workshop Exercise - Remove and Replace Camshafts

Fit thrust bearing flange (1) as shown in illustration.

Check dowel sleeves (2) for damage and correct installation position.

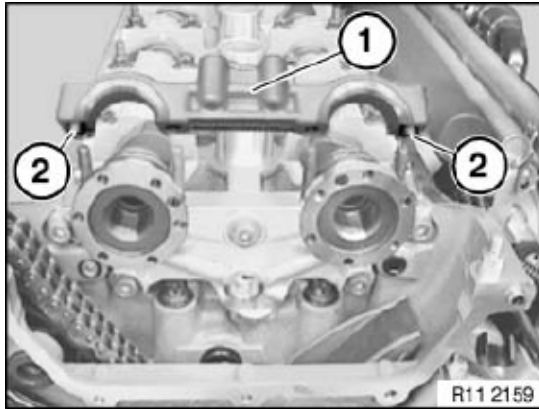

Align thrust bearing flange (1) by hand until it is secured to cylinder head by means of adapter sleeves.

Install nuts of thrust bearing flange (1).

Manually tighten nuts and then tighten down from in 1/2 turn increments.

Install toothed sleeves (3) of exhaust and inlet camshafts.

Align bores in toothed sleeves (3) to tapped holes in camshafts.

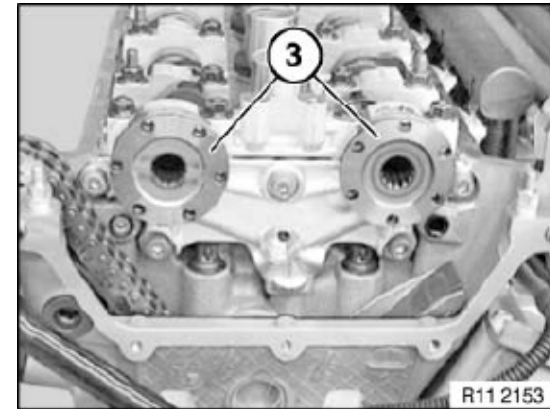

Install the thrust washers on the camshafts.

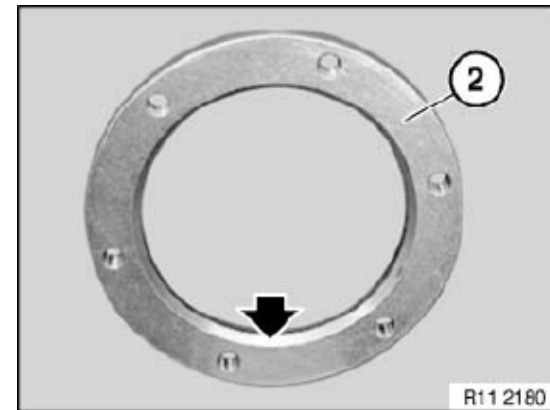

Note installation direction of thrust washers (2) below.



Workshop Exercise - Remove and Replace Camshafts

Install the centering sleeve (1) on EXHAUST and INTAKE sides with thrust washer (2).

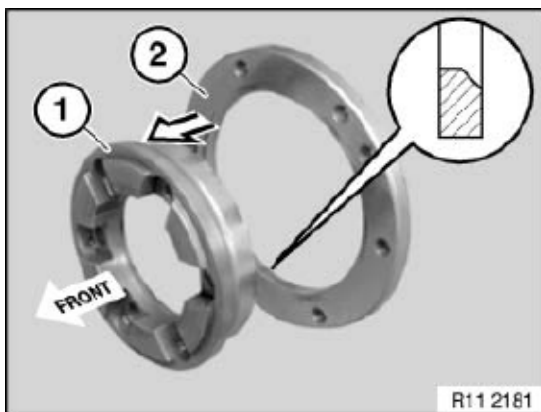

Grip camshafts at hexagon head.

Tighten down bolts on centering sleeves (1).

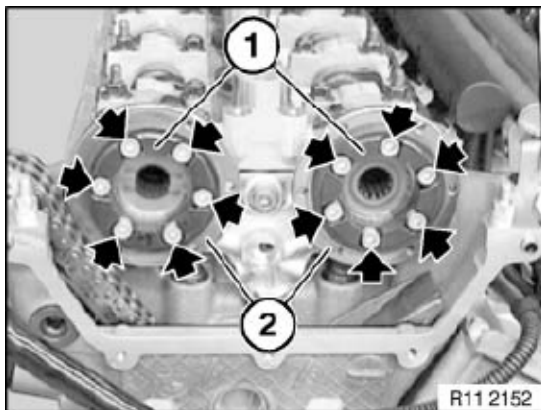

Attach special tool 11 9 130 to cylinder head.

Align INTAKE camshaft at hexagon until special tool 11 7 342 can be joined by means of special tool 11 9 130 in locating hole.

Note: Special tool 11 9 130 must rest flat on cylinder head.

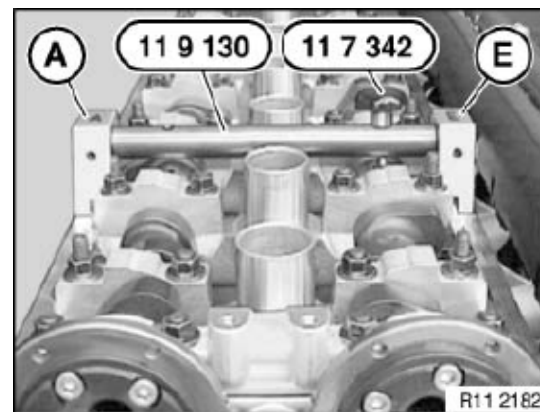

Remove special tool 11 7 342.

Align EXHAUST camshaft with hexagon until special tool 11 7 342 can be joined by means of special tool 11 9 130 in locating hole.

Note: Special tool 11 9 130 must rest flat on cylinder head.

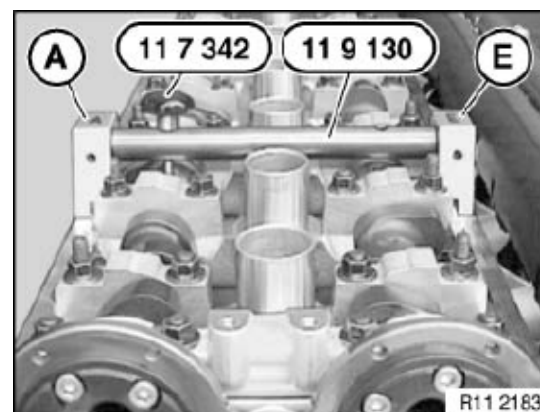

Remove special tool 11 9 130 and special tool 11 7 342.



Workshop Exercise - Remove and Replace Camshafts

Lift timing chain and hold under tension.

Rotate crankshaft from 30° before TDC position in direction of rotation up to TDC firing position.

Secure vibration damper in position with special tool 11 2 300.

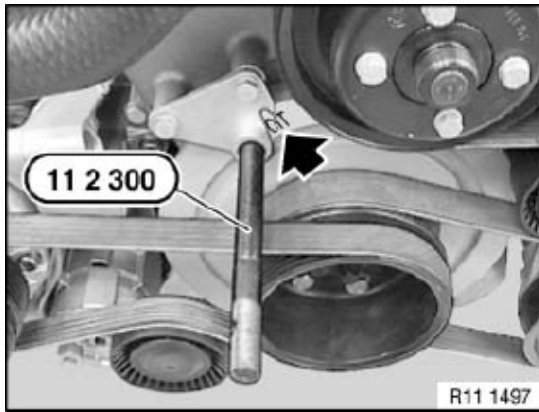

Install sprocket wheel (2) on INTAKE side on centering sleeves in such a way that elongated holes are centrally located.

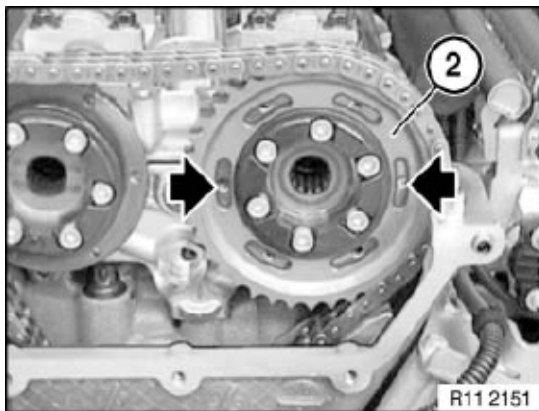

Hold timing chain under tension and feed on sprocket wheel (1).

Install sprocket wheel (1) on EXHAUST side on centering sleeves in such a way that elongated holes of sprocket wheels (1 and 2) are centrally located.

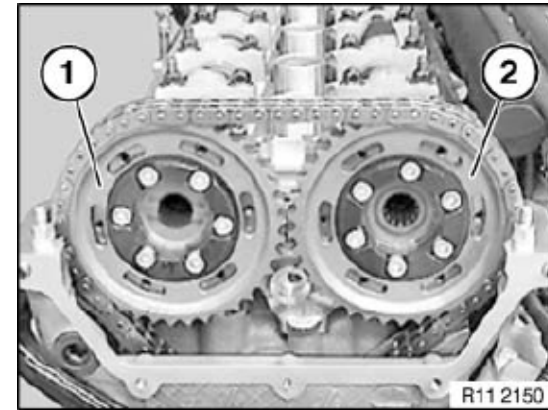

Press tensioning rail against timing chain and check position of elongated holes.

Why is centering the bolt holes on the elongated holes important?

Install the chain tensioner.

What must be done if the chain tensioner being reused?



Workshop Exercise - Remove and Replace Camshafts

Insert plate spring (2) and supporting ring (3) in tooth hub (1) of the EXHAUST side.

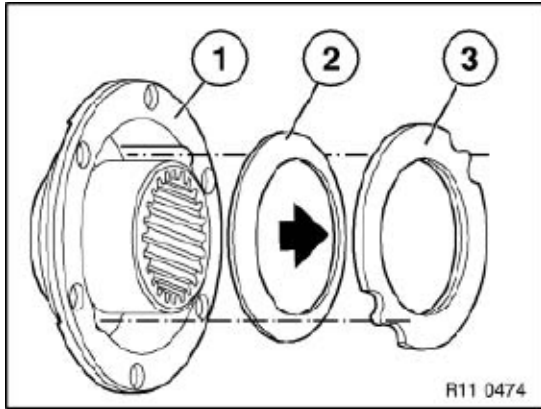

Note how the inner plate spring is installed below.

Install exhaust spline hub with plate spring and supporting ring.

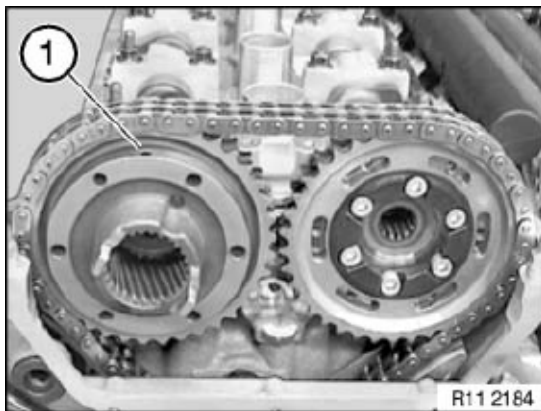

Bore hole (1) must point upwards as shown in illustration.

Insert all spline hub (1) bolts and tighten by hand until free of play.

Then loosen all bolts again until spline hub (1) can be moved with fingers.

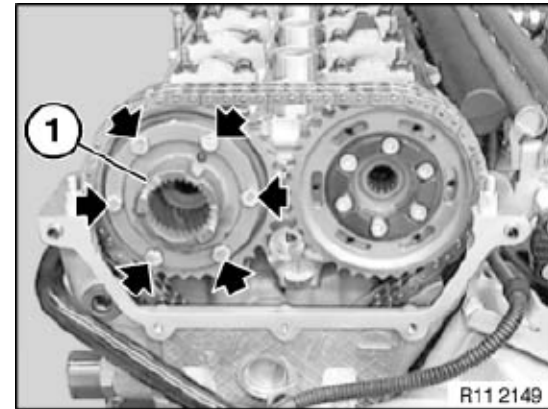

Insert plate spring (2) and supporting ring (3) in tooth hub (1) on the INTAKE side.

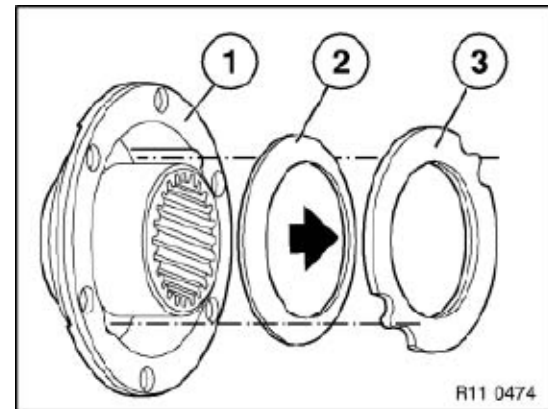



Workshop Exercise - Remove and Replace Camshafts

Install the INTAKE spline hub with plate spring and supporting ring.

Bore hole (1) must point upwards as shown in illustration.

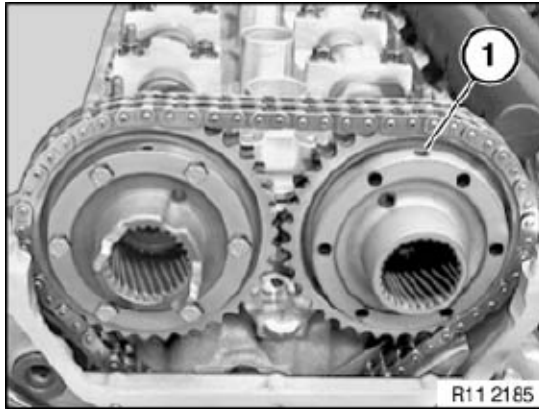

Insert all spline hub (1) bolts and tighten by hand until free of play.

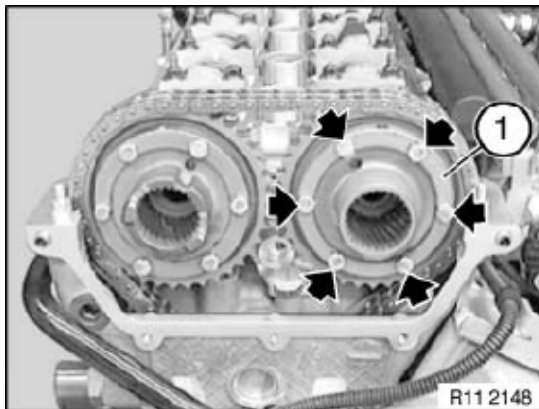

Then loosen bolts again until spline hub (1) can be moved with fingers.

*Replace the control valve sealing O rings (1) and coat with oil.
Insert the control valve into the cylinder head as shown in the illustration.*

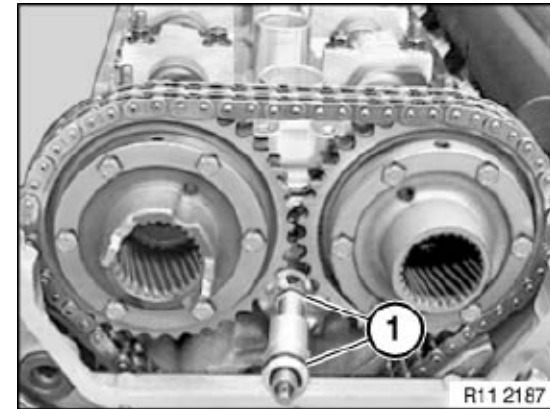

What special component is integrated into the control valve?

When must the control valve be replaced?



Workshop Exercise - Remove and Replace Camshafts

Connect special tool 12 6 050 in conjunction with special tool 12 6 411 (from special tool kit 12 6 410) to solenoid valves of VANOS adjustment unit.

Connect special tool 12 6 411 to correct terminals on car battery.

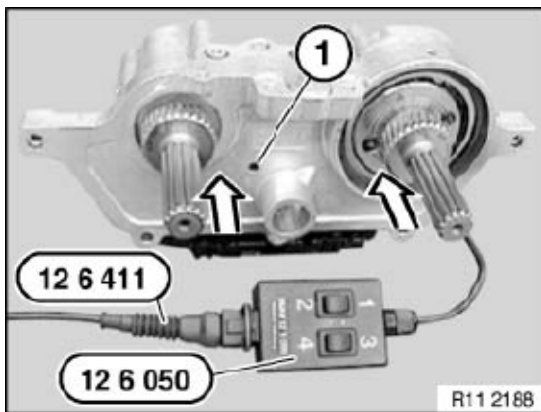

Press buttons 1 and 3 on special tool 12 6 050 simultaneously. Solenoid valves are actuated. Press splined shafts by hand up to stop into initial position.

Check dowel sleeves (1) for damage and correct installation.

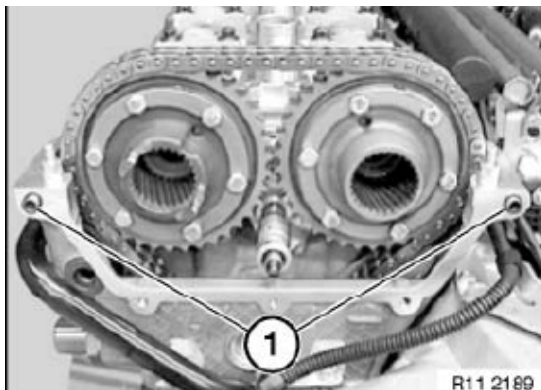

Secure gasket (1) with sealing compound on adapter sleeves.

Secure special tool 11 9 170 as shown in illustration by means of stud bolt.

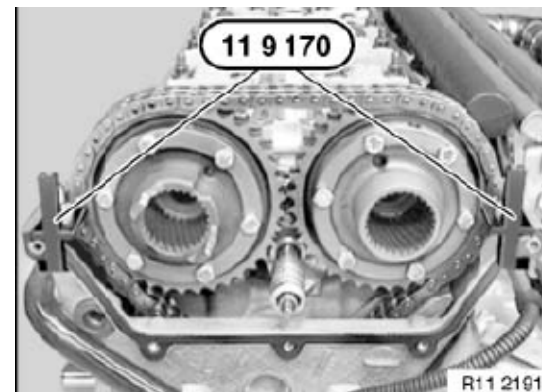

What is the purpose of special tool 11 9 170?

Turn spline hubs (1) of inlet and exhaust camshafts to right limit position.

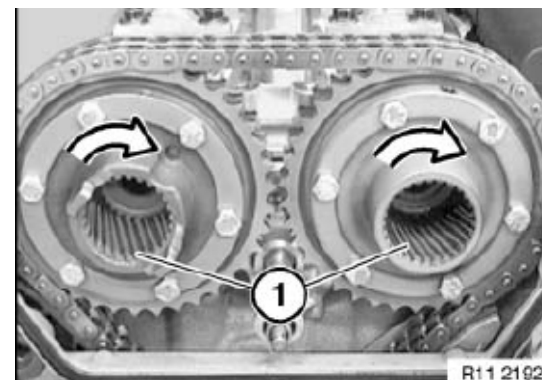



Workshop Exercise - Remove and Replace Camshafts

Attach VANOS adjustment unit leaving special tool 11 9 170 in place between the cylinder head and the VANOS adjustment unit.

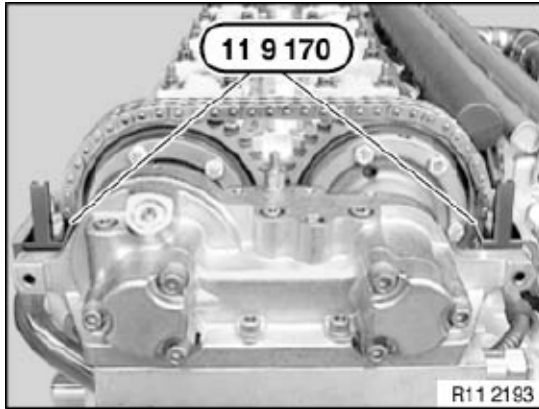

Note: Make sure both VANOS splined shafts remain in initial position during installation.

Rotate splined shafts of INTAKE and EXHAUST sides until the teeth engage.

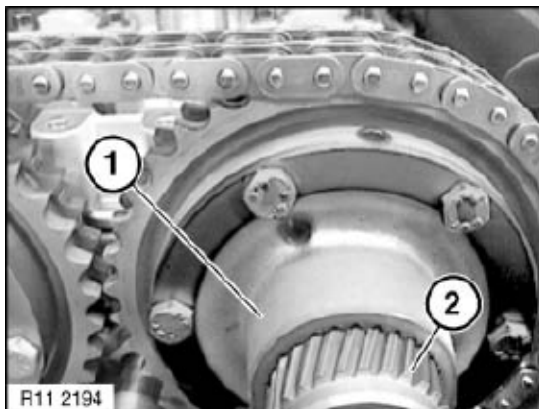

Push VANOS adjustment unit with splined shaft into VANOS gear until helical cut splines (2) are positioned shortly before meshing with spline hub (1).

If the helical cut splines cannot be pushed into the spline hub (1):

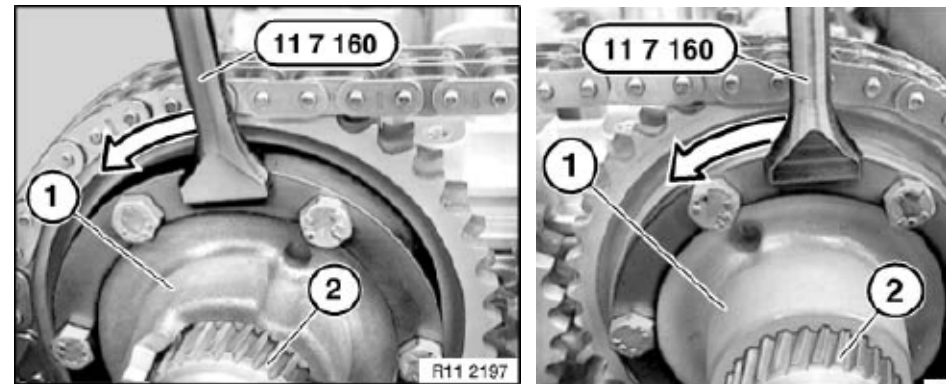

Place special tool 11 7 160 on hole in spline hubs (1). Rotate spline hub (1) against direction of rotation until splined shaft (2) is positioned with spline hub (1) exactly "tooth-to-tooth gap".

The "first" matching tooth must engage.

Align radial piston pump to driver on spline hub as illustrated.

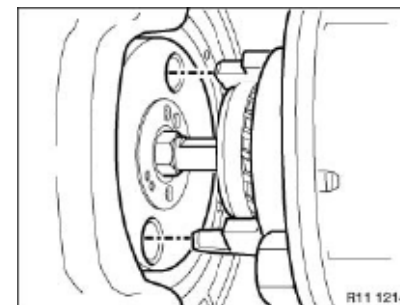



Workshop Exercise - Remove and Replace Camshafts

Push on VANOS adjustment unit until it contacts special tool 11 9 170 as shown below.

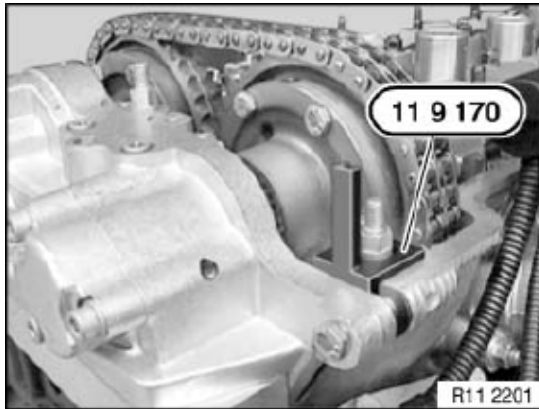

What must be done if this position can not be achieved?

Insert a bolt on left and right side of the VANOS Unit and tighten by hand until free of play.

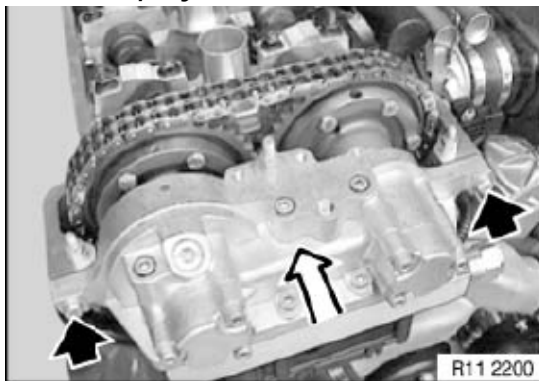

Why is it necessary to provide a specified gap with the special tool 11 9 170 between the cylinder head and VANOS adjustment unit?

Use special tool 11 7 200 and tighten down the two opposing bolts on the INTAKE and EXHAUST sides of the VANOS gear to 14 Nm.



Then loosen all four bolts by a 1/4 turn.

Remove special tool 11 9 170 on left and right sides.

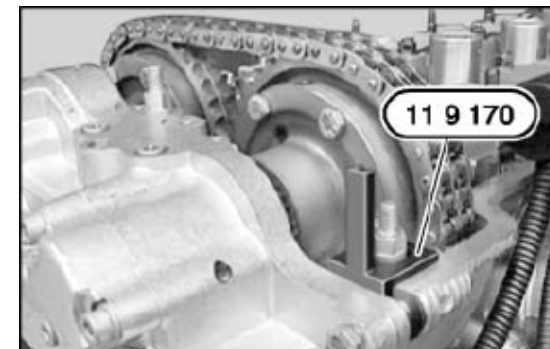



Workshop Exercise - Remove and Replace Camshafts

CAUTION!!!

Make sure that radial piston pump is aligned to drive on spline hub.

When the left and right bolts are tightened down alternately, the exhaust and intake camshafts must not rotate.

Note: If the camshafts do rotate, this means that the bolts on the VANOS gear were not previously released correctly.

Alternately tighten down bolts in 1/2 turn increments carefully and evenly until VANOS adjustment unit rests against timing case cover.

Insert remaining bolts and tighten them down to specifications.

Use special tool 11 7 200 to tighten down bolts on VANOS gear.

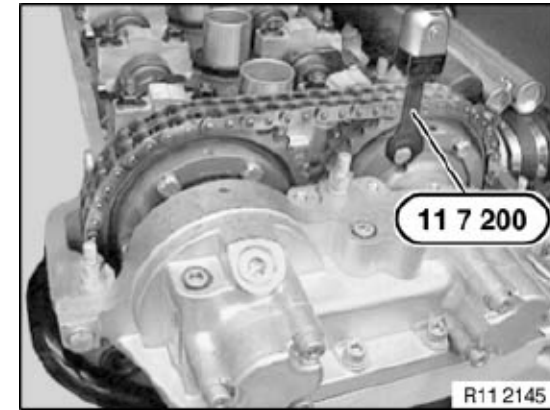

Tighten down six accessible bolts (three on exhaust side and three on intake side) on VANOS gear to 14 Nm.

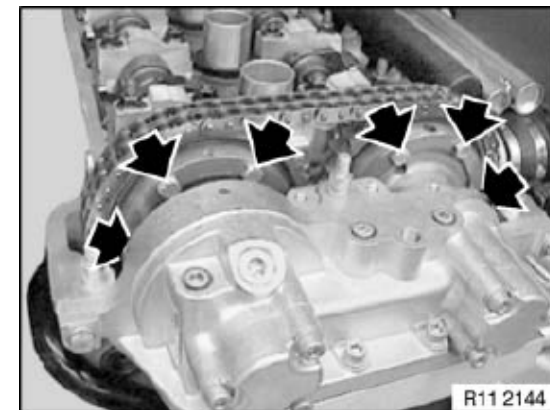



Workshop Exercise - Remove and Replace Camshafts

Remove special tool 11 2 300. Rotate crankshaft in direction of rotation a further revolution up to the overlap TDC position as shown below.

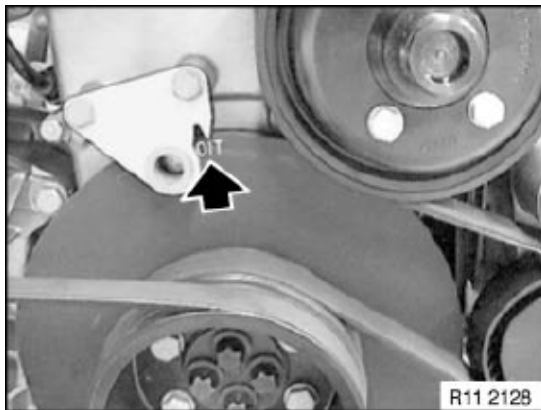

Use special tool 11 7 200 to tighten down bolts on VANOS gear.

Tighten down remaining six bolts (three on exhaust side and three on intake side) on VANOS gear to 14 Nm.

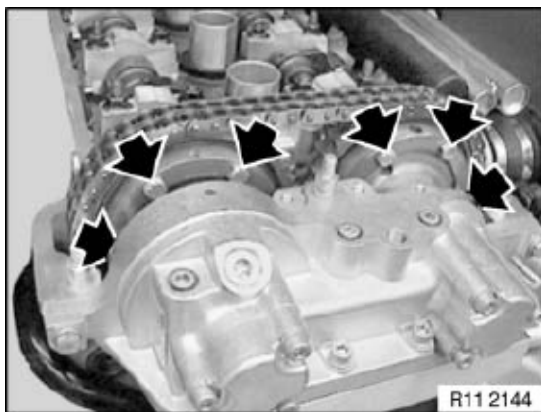

Then crank engine again in direction of rotation until cylinder #1 is at TDC firing position.

Secure vibration damper in position with special tool 11 2 300.

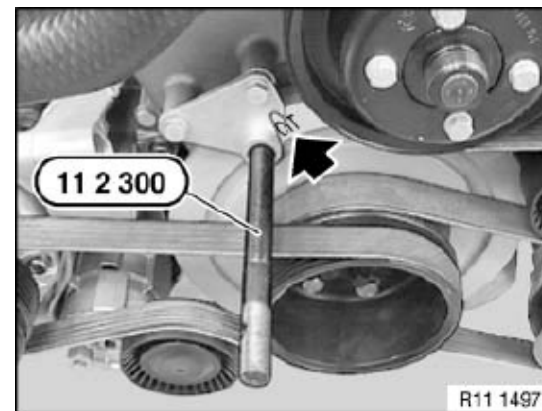

Check camshaft timing:

Attach special tool 11 9 140 and connect to the intake camshaft.

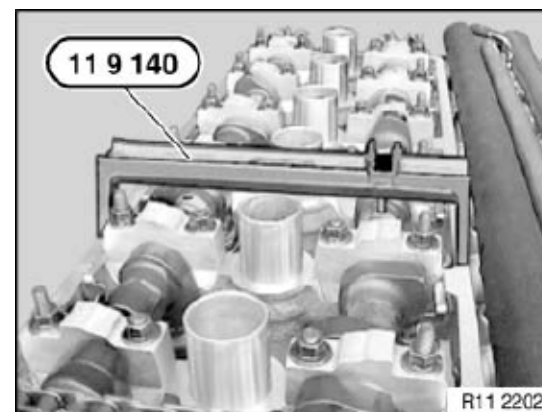

The tool must sit flat or protrude by a max. of 0.5 mm on the exhaust side when the intake camshaft is correctly adjusted.



Workshop Exercise - Remove and Replace Camshafts

Install special tool 11 9 140 and connect to the EXHAUST camshaft.

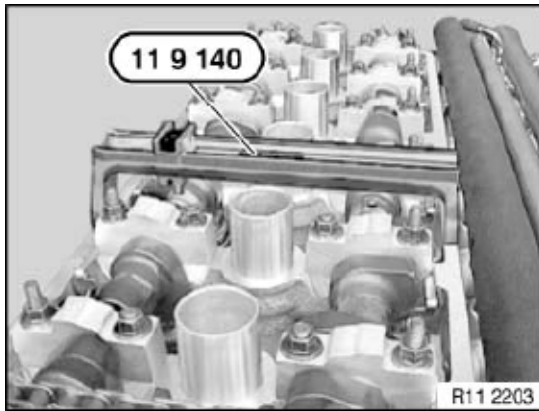

The tool must sit flat or protrude by a max. of 0.5 mm on the intake side when the exhaust camshaft is correctly adjusted.

Note: If the special tool 11 9 140 protrudes to the inlet side, the timing must be readjusted.

Install holder (4) and sliding rail (2).

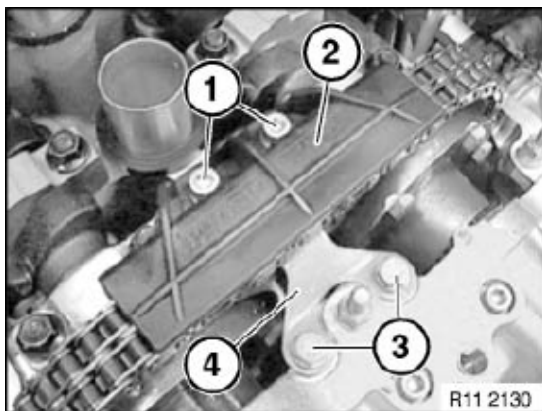

Replace sealing rings of banjo bolt. (In the field)

Insert banjo bolt but do not tighten down yet.

Install bracket of oil line. Install bolt and tighten down.

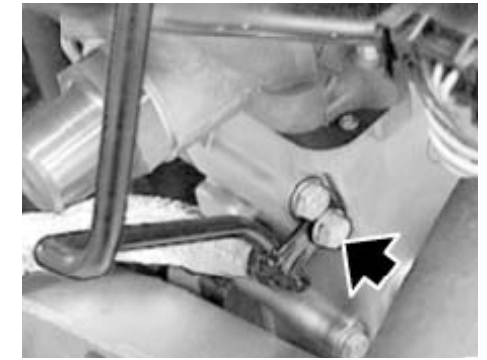

Tighten down banjo bolt of oil line to specifications

Remember to remove special tool 11 2 300.

Adjust valves. (In the field)

Assemble engine as per instructor instructions

What must be done if in the first few seconds after startup a "rattling noise" is heard?

NOTES

PAGE